

INSTAKNIGHT HOT WATER SYSTEMS

Why you should install a Kelvinator InstaKnight hot water system:

- Designed to hang on an outside wall or out of sight, recessed into an outside wall
- Superior efficiency with up to 6 Energy Stars
- Either 50°C or 60°C presets available
- Available in Natural Gas or LPG versions
- Only suitable for external installation
- Must be wall mounted, either hanging on the outside of the wall or out of sight recessed in the wall
- Metal recess box and pipecovers available
- Up to 3 wall-mounted remote control pads available for easy and convenient water temperature selection

Electrolux Home Products warrants that the Kelvinator models featured in this flyer are free from defects in materials and workmanship for periods listed in the table below:

Kelvinator hot water system components Warranty	Heat exchanger	All other components
Component	10 years	3 years
Labour	3 years	3 years



KGC20BNA



KGC26KNA



Recess box
KGCRB1C

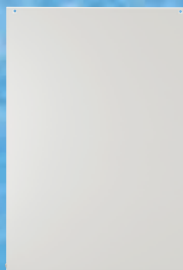

Pipe cover 26
KGPC26A

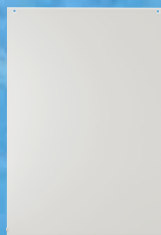

Pipe cover 20
KGPC20A



Main remote controller
60° preset
KGCMRCB



Shower remote controller
KGCSRCB



Ensuite remote controller
KGCERCB



Main 50 remote controller
50° preset
KGCMRCC

Australians love
a Kelvinator



Kelvinator InstaKnight specifications

Product code	KGC20BNA / KGC20BLA	KGC20KNA / KGC20KLA	KGC26BNB / KGC26BLB	KGC26KNA / KGC26KLA
Number of bathrooms	1 - 1.5	1 - 1.5	1.5 - 3	1.5 - 3
Gas continuous location	outdoor	outdoor	outdoor	outdoor
Type of gas	natural gas / LPG	natural gas / LPG	natural gas / LPG	natural gas / LPG
Gas continuous unit net weight (kg)	15.7	15.7	17.2	17.2
Technical specifications				
Gas energy star rating	6	6	6	5.3
Flow rate capacity (L/min 25°C rise)	20	20	26	26
Maximum temperature (°C)	50	60	50	60
Gas inlet supply pressure min-max (kPa) - NG / LPG	1.13 - 2.75 / 2.61 - 2.89	1.13 - 2.75 / 2.61 - 2.89	1.13 - 2.75 / 2.61 - 2.89	1.13 - 2.75 / 2.61 - 2.89
Nominal gas consumption (MJ/h)	160	160	195	195
Water connections & settings				
Water supply pressure min - max (kPa)*	150 - 1200	150 - 1200	150 - 1200	150 - 1200
Water connection (mm)	15 BSP	15 BSP	15 BSP	15 BSP
Gas connection (mm)	20 BSP	20 BSP	20 BSP	20 BSP
Additional accessories				
Recess box	KGCRB1C	KGCRB1C	KGCRB1C	KGCRB1C
Pipecover	KGCP20A	KGCP20A	KGCP26A	KGCP26A
Remote control†	KGCMRCC	KGCMRCB	KGCMRCC	KGCMRCB
Shower remote control	KGCSRCB	KGCSRCB	KGCSRCB	KGCSRCB
Ensuite remote control	KGCERCB	KGCERCB	KGCERCB	KGCERCB

*The water heater will operate at reduced performance if inlet water supply pressure is below 340 kPa.
 † Remote controller not water resistant therefore not suitable for bathroom installation.

Dimensions (refer to diagram below)

Flowrate	20L/min	26L/min
A Height (mm)	520	520
B Width (mm)	350	350
C Depth (mm)	170	215
D Distance from back of unit to cold water inlet (mm)	30	45
E Distance from back of unit to hot water outlet (mm)	100	140
F Distance from back of unit to gas inlet (mm)	70	110

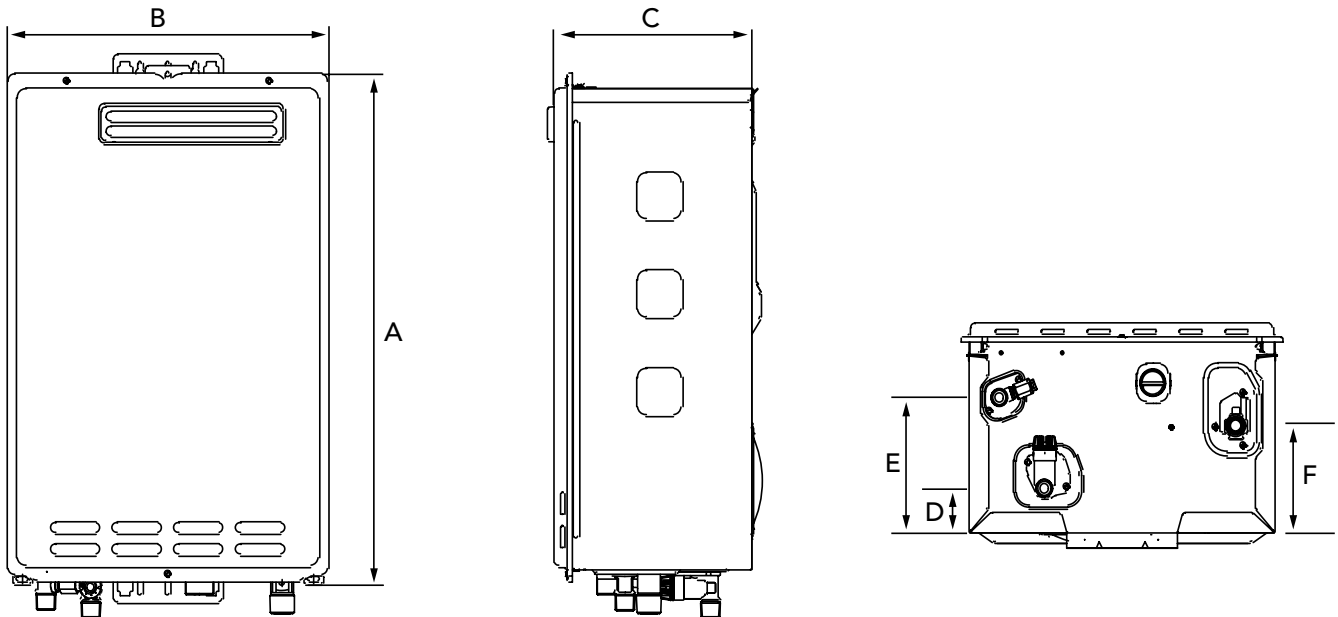

Product information
 The descriptors and illustrations in this publication apply to the specific products and models described as at the date of issue. Under our policy of continuous product development, product specifications may change without notice. Prospective purchasers should therefore check with their retailer to ensure this publication correctly describes the products that are being offered for sale. All information supplied is to be used for general reference purposes only and is on the understanding that Electrolux Home Products Pty Ltd will not be liable for any loss, liability or damage of whatever kind arising as a result of reliance on such information. Colours of products illustrated are as close as printing limitations allow. Electrolux will at all times comply with its obligation pursuant to law including Trade Practices (Australian Consumer Law) Act and Regulations.

Electrolux Home Products Australia
 telephone: 13 62 26 fax: 1800 350 067 web: kelvinator.com.au
Kelvinator. We are part of the Electrolux family. Share more of our thinking at electrolux.com.au
 © 2015 Electrolux Home Products Pty Ltd. KHWSFS_IK_Aug15

