

INSTANTANEOUS GAS HOT WATER

QUANTUM GAS MODELS

6 STAR EFFICIENCY



ENDLESS SUPPLY OF
HOT WATER,
THE CONTINUOUS FLOW RANGE



TECHNICAL SPECIFICATION

6 STAR EFFICIENCY



Models	QI-6S-20NG/LPG	QI-6S-26NG/LPG
Gas Input (MJ/h)	150	195
Performance (Litres/min)*	20	26
Gas Inlet Pressure (kPa - NG)	1.13 min - 2.75 max	1.13 min - 2.75 max
Gas Inlet Pressure (kPa - LPG)	2.75 min/max	2.75 min/max
Water Supply Pressure (kPa)	150 min - 1200 max	150 min - 1200 max
Preset temperature	50°C	50°C
Height (mm)	520	520
Depth (mm)	170	215
Width (mm)	350	350
Weight (kg)	15	17
Gas Connection (mm)	20 BSP	20 BSP
Water Connections (mm)	15 BSP	15 BSP
Ignition	Electronic	Electronic
Electrical Supply (V)	240 AC	240 AC
Installation	Outdoor	Outdoor
Heat Exchange Warranty	10 years	10 years
Parts and Labour Warranty	3 years	3 years

* Performance At 25°C temperature rise

Safety devices

- Flame detector / Air-Flue ratio sensor
- Over heat cut off fuse / Fan motor rotation detector
- Flow rate detector / Hot water high limit switch
- Internal Freeze protection system

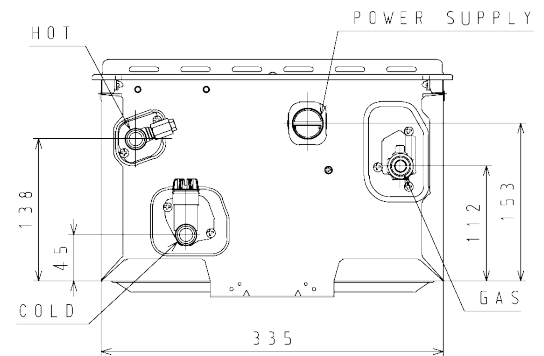
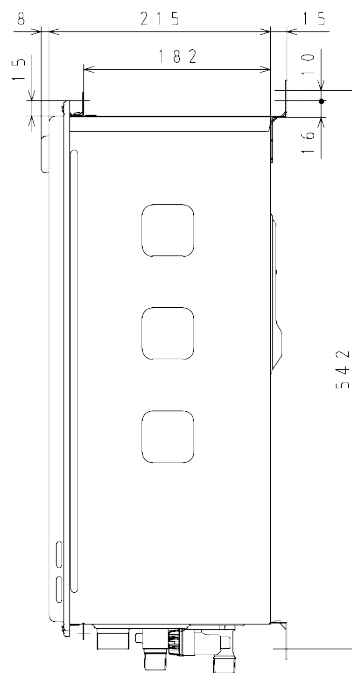
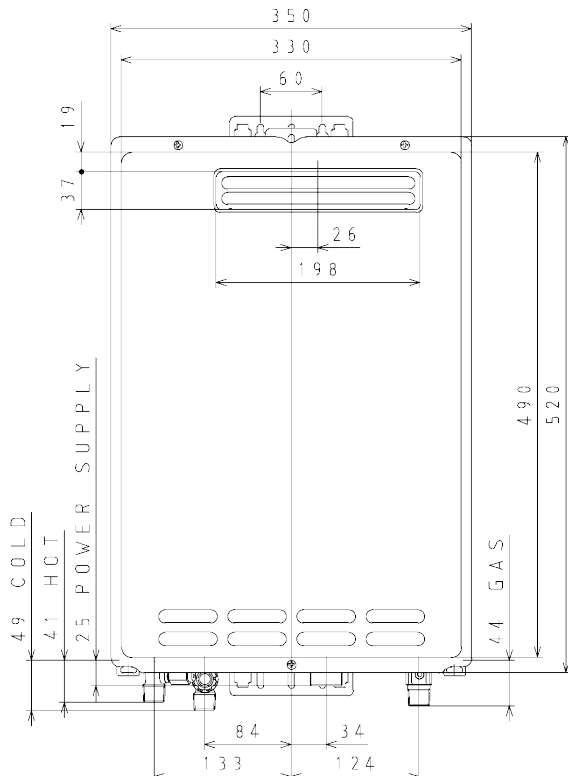

*Dimensions are in mm. Diagram pictured above is for the Quantum Gas Continuous Flow Model QI-6S-26NG/LPG.

For more information please visit www.quantumenergy.com.au or call us on **1800 383 888**

