



# STELLAR®

## RHEEM STELLAR® GAS HOT WATER



GAS

1-6  
PEOPLE

MAINS  
PRESSURE

10 YEAR  
CYLINDER  
WARRANTY<sup>1,2</sup>



### RHEEM STELLAR® 330 & 360

- **5 Star energy efficiency** – uses less gas than 3 or 4 Star water heaters
- **Advanced technology** – the Stellar Superflue® increases efficiency and performance, reducing energy consumption to save you money
- **Mains pressure** – to service multiple hot water demands at once
- **200L/hour hot water recovery** – more than you will likely need!
- 10 Year cylinder warranty<sup>1</sup>
- 330 or 360L first hour capacity<sup>3</sup>
- Australian made

### RHEEM STELLAR® 330 STAINLESS STEEL

- **5 Star energy efficiency**
- **Stainless Steel Cylinder**
- **185L/hour hot water recovery<sup>5</sup>** – enough for large families
- **Up to 50L/hour additional hot water recovery** (depending on temperature chosen) via the inbuilt adjustable mixing valve<sup>6</sup>
- **Mains pressure** – to service multiple hot water demand at once
- 10 Year cylinder warranty<sup>2</sup>
- Australian made



COMES ON STEADY, HOT AND STRONG

INSTALL A





# STELLAR®

## THE BEST IN GAS HOT WATER

Rheem Stellar® is synonymous with the best in gas hot water, providing superior energy efficiency and hot water recovery.

Now Rheem Stellar® adds even more innovation and performance with the addition of Stellar Stainless Steel to the range.

## THE STAINLESS STEEL ADVANTAGE

The stainless steel cylinder in selected Rheem Stellar® models not only offers purity and durability, it can help save money in the long run.

- Can resist corrosion for longer than conventional vitreous enamel cylinders
- No sacrificial anode, for reduced lifetime service costs
- Superior energy efficiency

**Rheem Stellar® Stainless Steel water heaters are not recommended for installation in some areas. Refer to the Rheem website [www.rheem.com.au](http://www.rheem.com.au) for details of areas not recommended and for which product is not covered by warranty.**

### Rheem® Stellar 330/360

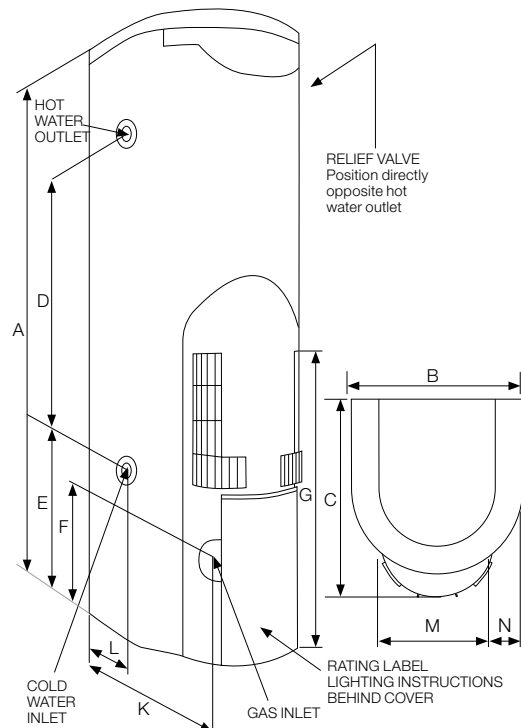

SPECIFICATIONS	850330	850360	8A0330 STAINLESS STEEL
AGA Star Rating Index	5 Stars	5 Stars	5 Stars
<b>Suitable for Number of People</b>			
Moderate Climate	2-5	3-6	3-6
Cool Climate	2-4	3-5	3-5
Storage Capacity	Litres 130	160	155
Recovery Rate at 45°C Rise	Litres/Hr 200	200	185
First Hour Capacity <sup>3</sup>	Litres 330	360	340
<b>Hourly Gas Consumption</b>			
Natural Gas	MJ/Hr 42	42	40
Approx. Weight Empty	kg 70	80	65
Approx. Weight Full	kg 200	240	220
Relief Valve Setting	kPa 1400	1400	1400
Expansion Control Valve Setting	kPa 1200	1200	1200
<b>Max. Water Supply Pressure</b>			
Without ECV	kPa 1120	1120	1120
With ECV <sup>4</sup>	kPa 960	960	960
Water Connection LHS	RP¾"/20	RP¾"/20	RP¾" (20mm) Female
Gas Connection	RP½"/15	RP½"/15	½" Flared Compression
Installation Type	External Only	External Only	External Only
Warranty (Cylinder) <sup>1,2</sup>	10 Years	10 Years	10 Years
<b>Dimensions</b>			
A (Height)	mm 1600	1900	1625
B (Width) Approx.	mm 485	485	520
C (Depth) Approx.	mm 558	558	610
D	mm 988	1213	60
E	mm 328	409	333
F	mm 298	298	360
G	mm 770	770	840
K	mm 520	520	-
L	mm 252	252	-
M	mm 299	299	415
N	mm 93	93	52

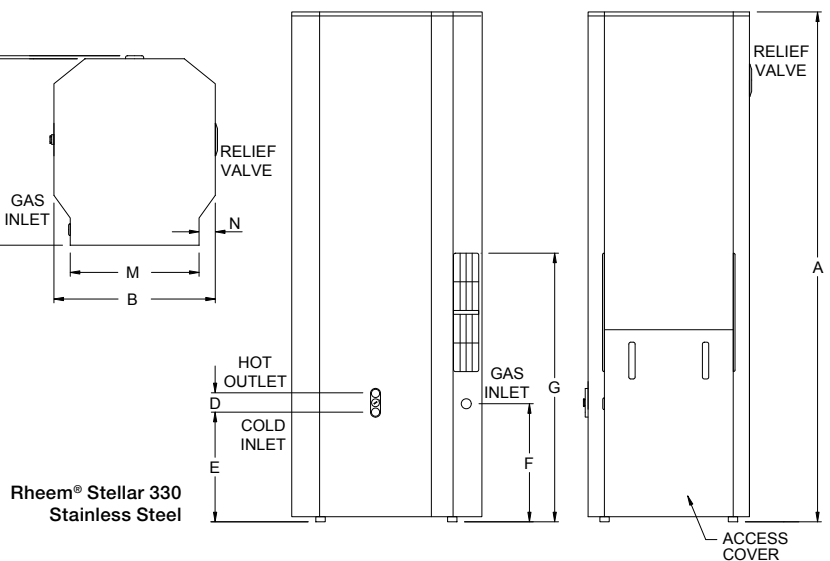

1. Rheem Stellar 330/360 warranty: 10 Years Cylinder and SuperFlue® Warranty, 5 Years labour on Cylinder and SuperFlue®, 1 Year parts & labour warranty on all other components. For Domestic (non-commercial) installations. 2. Rheem Stellar 330 Stainless Steel Warranty: 10 year cylinder warranty, 1 year parts and labour warranty on all other components for domestic (non-commercial) installations. Conditions apply. See the Rheem warranty set out in the Owner's Guide & Installation Instructions or view it at [www.rheem.com.au/warranty](http://www.rheem.com.au/warranty). 3. First hour capacity is the storage capacity plus nominal first hour recovery rate at 45°C temperature rise using Natural Gas. 4. ECV not supplied. 5. At 45°C temperature rise. 6. Guide only. Based on a cold water temperature of 15°C.

Materials and data are subject to change without notice. ®Registered Trademark of Rheem Australia Pty Ltd. ™Trademark of Rheem Australia Pty Ltd.

Rheem Australia Pty Ltd.

1 Alan Street, Rydalmere, New South Wales 2116, Australia  
PO Box 6, Rydalmere, New South Wales 2116, Australia

