

# OPERATION AND INSTALLATION

---

DHW heat pump

- » WWK 222
- » WWK 222 H
- » WWK 302
- » WWK 302 H

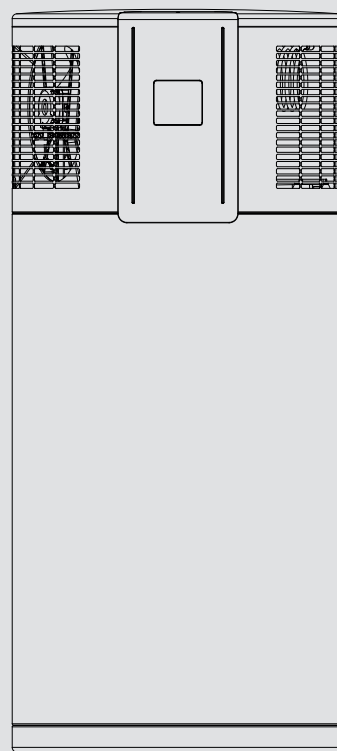

**STIEBEL ELTRON**

# CONTENTS

## SPECIAL INFORMATION

### OPERATION

<b>1. General information</b>	<b>4</b>
1.1 Safety instructions	4
1.2 Other symbols in this documentation	4
1.3 Units of measurement	4
<b>2. Safety</b>	<b>4</b>
2.1 Intended use	4
2.2 General safety instructions	4
2.3 Test symbols	5
<b>3. Appliance description</b>	<b>5</b>
3.1 Heat pump operating principle	6
3.2 DHW heating	6
3.3 Appliance operation outside the application limits	6
3.4 Frost protection	6
3.5 Minimum runtime and minimum pause time	7
3.6 Connection of an external signal transmitter	7
<b>4. Settings</b>	<b>7</b>
<b>5. Cleaning, care and maintenance</b>	<b>7</b>
<b>6. Troubleshooting</b>	<b>9</b>

### INSTALLATION

<b>7. Safety</b>	<b>10</b>
7.1 General safety instructions	10
7.2 Instructions, standards and regulations	10
<b>8. Appliance description</b>	<b>10</b>
8.1 Standard delivery	10
8.2 Required accessories	10
8.3 Further accessories	10
8.4 Incorrect use	10
<b>9. Preparations</b>	<b>10</b>
9.1 Transport	10
9.2 Storage	11
9.3 Installation site	11
9.4 Siting the appliance	12
<b>10. Installation</b>	<b>13</b>
10.1 Water connection	13
10.2 Condensate drain	14
10.3 Power supply	14
10.4 Assembling the appliance	17
<b>11. Commissioning</b>	<b>18</b>
11.1 Initial start-up	18
11.2 Recommissioning	18
<b>12. Shutdown</b>	<b>18</b>
<b>13. Troubleshooting</b>	<b>19</b>
13.1 Resetting the safety pressure limiter	19
13.2 Resetting the high limit safety cut-out (only WWK H)	19
13.3 Motor overload relay	19
<b>14. Maintenance</b>	<b>20</b>
14.1 Removing the appliance cover	20
14.2 Removing the casing ring	20
14.3 Cleaning the evaporator	20
14.4 Draining the cylinder	21
14.5 Descaling the electric emergency/booster heater	21

14.6 Valves	21
14.7 Condensate drain	21
14.8 Replacing the power cable	21
14.9 Fitting the casing ring	21
14.10 Fitting the appliance cover	21
<b>15. Specification</b>	<b>22</b>
15.1 Dimensions and connections	22
15.2 Wiring diagram	24
15.3 Data table	26

### WARRANTY

### ENVIRONMENT AND RECYCLING

## SPECIAL INFORMATION

- The appliance may be used by children aged 8 and older and persons with reduced physical, sensory or mental capabilities or a lack of experience and know-how, provided that they are supervised or they have been instructed on how to use the appliance safely and have understood the resulting risks. Children must never play with the appliance. Children must never clean the appliance or perform user maintenance unless they are supervised.
- Observe all applicable national and regional regulations and instructions.
- Observe the minimum clearances (see chapter "Installation / Preparations / Siting the appliance").
- Observe the requirements concerning the installation room (see "Specification / Data table").
- The connection to the power supply must be in the form of a permanent connection. Ensure the appliance can be separated from the power supply by an isolator that disconnects all poles with at least 3 mm contact separation. Contactors, circuit breakers or fuses can be used for this. This type of isolator must be installed in the fixed electrical installation according to the wiring rules. For Australia: Ensure that the appliance can be separated from the power supply by a suitable isolator. Contactors, circuit breakers or fuses can be used for this. This type of isolator must be installed in accordance with the wiring rules.
- Observe the safety measures to prevent contact with dangerous 'live' currents.
- Observe the MCB/fuse protection required for the appliance (see chapter "Specification / Data table").
- If the power cable is faulty, replace it with a new one. The power cable must only be replaced (for example if damaged) by a qualified contractor.
- The appliance is pressurised. During the heat-up process, expansion water will drip from the safety valve.
- Activate any valves at least once every 6 months to prevent blockages, e.g. by limescale deposits.
- Drain the appliance as described in "Installation / Maintenance and cleaning / Draining the cylinder".
- A T&P valve or a safety valve (cold water expansion control valve) must be installed. Observe all applicable national and regional regulations and instructions.
- The maximum pressure in the cold water supply line must be at least 20 % below the response pressure of the lowest pressure rated valve installed, otherwise a pressure reduction valve will be required. If this is the case, install a pressure reduction valve in the cold water feed. The pressure reducing valve must be set to 440 kPa if a safety valve is installed; otherwise to 550 kPa.
- Fit the discharge pipe of the safety valve with a constant downward slope and in a room free from the risk of frost.
- Size the drain so that water can drain off unimpeded when the safety valve is fully opened.
- The safety valve discharge aperture must remain open to atmosphere.

## OPERATION

## 1. General information

The chapters "Special Information" and "Operation" are intended for both the user and qualified contractors.

The chapter "Installation" is intended for qualified contractors.

**Note**

Read these instructions carefully before using the appliance and retain them for future reference. Pass on the instructions to any new user where appropriate.

## 1.1 Safety instructions

## 1.1.1 Structure of safety instructions

**KEYWORD Type of risk**

Here, possible consequences are listed that may result from failure to observe the safety instructions.

► Steps to prevent the risk are listed.

## 1.1.2 Symbols, type of risk

Symbol	Type of risk
	Injury
	Electrocution
	Burns (burns, scalding)

## 1.1.3 Keywords

KEYWORD	Meaning
DANGER	Failure to observe this information will result in serious injury or death.
WARNING	Failure to observe this information may result in serious injury or death.
CAUTION	Failure to observe this information may result in non-serious or minor injury.

## 1.2 Other symbols in this documentation

**Note**

General information is identified by the adjacent symbol. ► Read these texts carefully.

Symbol	Meaning
	Material losses (appliance damage, consequential losses and environmental pollution)
	Appliance disposal

► This symbol indicates that you have to do something. The action you need to take is described step by step.

## 1.3 Units of measurement

**Note**

All measurements are given in mm unless stated otherwise.

## 2. Safety

## 2.1 Intended use

The purpose of this appliance is to heat domestic hot water within the application limits stated in the chapter "Specification / data table".

This appliance is intended for domestic use. It can be used safely by untrained persons. The appliance can also be used in a non-domestic environment, e.g. in a small business, as long as it is used in the same way.

Any other use beyond that described shall be deemed inappropriate. Observation of these instructions and of instructions for any accessories used is also part of the correct use of this appliance.

## 2.2 General safety instructions

Operate the appliance only when fully installed and with all safety equipment fitted.

**WARNING Injury**

The appliance may be used by children aged 8 and older and persons with reduced physical, sensory or mental capabilities or a lack of experience and know-how, provided that they are supervised or they have been instructed on how to use the appliance safely and have understood the resulting risks. Children must never play with the appliance. Children must never clean the appliance or perform user maintenance unless they are supervised.

**WARNING Electrocution**

Contact with live components presents a threat to life. Damage to the cable insulation or to individual components may result in a risk to life.

► If there is damage to the insulation, switch off the power supply and arrange a repair.

All work on the electrical installation must be carried out by a qualified contractor.



**WARNING Burns**  
The water in the DHW cylinder can be heated to temperatures in excess of 60 °C. There is a risk of scalding at outlet temperatures in excess of 43 °C.  
▶ Ensure you do not come into contact with the water when discharged.



**WARNING Burns**  
Touching hot components can lead to burns.  
▶ When working on hot components, always wear protective working clothing and safety gloves. The pipework connected to the DHW outlet of the appliance can reach temperatures in excess of 60 °C.



**WARNING Burns**  
The appliance is filled with refrigerant at the factory. In the event of refrigerant escaping due to a leak, avoid coming into contact with the refrigerant or inhaling the released vapours. Ventilate the rooms affected.



**WARNING Electrocutation**  
Never operate the appliance when the casing is open or without a cover.



**CAUTION Injury**  
If objects are left on the appliance, noise emissions may increase due to resulting vibrations, and the objects could fall and cause injury.  
▶ Never place any objects on top of the appliance.



**Material losses**  
At the factory, the appliance is fitted with rechargeable batteries that ensure the power supply to the impressed current anode in the case of a power failure. To enable the impressed current anode to provide protection against corrosion, the power supply to the appliance must not be interrupted for more than 16 hours if the DHW cylinder is filled with water and the anode is not connected separately to a continuous power supply source. If regular interruptions to the power supply are not anticipated, the batteries will require no maintenance. Every three years, you must replace the batteries for the impressed current anode in the following cases:

- The impressed current anode is not connected separately to a continuous power supply source and a switching contact regularly interrupts the power supply to the appliance.
- The security of supply is inadequate.

Neglecting to do this puts the appliance at risk of damage. Never use batteries that cannot be charged. Only nickel-metal hydride (Ni-MH) rechargeable batteries are permissible. Batteries may be damaged in the appliance. Without a power supply, the impressed current anode and the cylinder would not be protected against corrosion.



**Material losses**  
Ensure that the appliance, the water pipes and safety valves are free from any risk of frost. If you disconnect the appliance from the power supply, it is no longer protected against frost.



**Material losses**  
Never cover the appliance. Covering the air intake or air discharge leads to a reduced air supply. If the air supply is restricted, the operational reliability of the appliance cannot be guaranteed.



**Material losses**  
Only operate the appliance when the DHW cylinder has been filled. If the DHW cylinder is empty, safety equipment switches off the appliance.



**Material losses**  
Heating liquids other than potable water is not permitted.



**Material losses**  
Keep the appliance installation site free from air contaminated with oil or salt (chloride) and corrosive or explosive substances. Avoid contaminating the installation site with dust, hairspray or substances containing chlorine or ammonia.



**Material losses**  
Operating the appliance outside the application limits (see "Specification / Data table") is not permitted. The appliance may be damaged if operated continuously outside the application limits.



**Note**  
The appliance is pressurised. During the heat-up process, expansion water will drip from the safety valve.  
▶ If water continues to drip when heating is completed, inform your qualified contractor.

**2.3 Test symbols**

See type plate on the appliance.

**3. Appliance description**

This appliance enables DHW to be supplied efficiently to several draw-off points using renewable energy. The appliance extracts heat from the ambient air. This heat is used to heat up the water in the DHW cylinder with added electric power. The amount of electrical energy and time required to heat up the DHW depend on the temperature of the air drawn in. When the air inlet temperature drops, the appliance output is reduced and the heat-up time is extended.

Subject to the power supply and user draw-off behaviour, the water is heated automatically to the selected set temperature. The appliance heats up the water to a temperature which is selected at the factory.

## Appliance description

In the case of indoor installation, the air inside the installation room can be cooled by 1 °C to 3 °C through heat extraction. The appliance also extracts moisture from the air, which turns into condensate. The condensate is removed from the appliance via the condensate drain.

When a hot water draw-off point is opened, the hot DHW is pushed out of the appliance by the inflow of cold water.

The heat pump drive unit is located in the upper section of the appliance. The DHW cylinder is located in the lower section of the appliance. To protect against corrosion, the DHW cylinder is coated internally with special enamel and is additionally equipped with an impressed current anode.

### 3.1 Heat pump operating principle

A closed circuit within the appliance contains refrigerant (see "Specification / Data table"). This refrigerant evaporates at low temperatures. In the evaporator, which extracts heat from the air drawn in, the refrigerant changes from a liquid into a gaseous state. A compressor draws in the gaseous refrigerant and compresses it. This increase in pressure raises the refrigerant temperature. That requires electrical energy.

The energy (motor heat) is not lost, but reaches the downstream condenser together with the compressed refrigerant. There, the refrigerant transfers heat to the DHW cylinder. An expansion valve then reduces the still prevalent pressure and the cyclical process starts again.

### 3.2 DHW heating

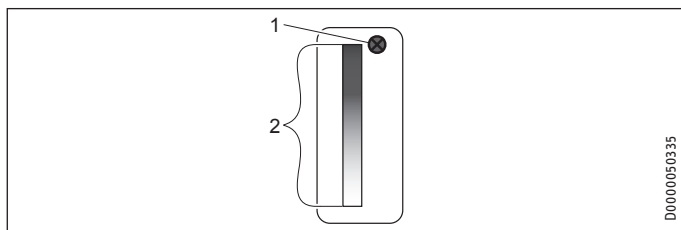

- 1 Cylinder top sensor
- 2 Integral sensor

The appliance is equipped with two temperature sensors.

- The cylinder top sensor captures the water temperature in the upper section of the cylinder.
- The integral sensor is a temperature sensor affixed over the entire cylinder height. The integral sensor determines the average cylinder temperature.

The appliance control unit uses the average cylinder temperature captured by the integral sensor. DHW heating is started when the average cylinder temperature has fallen below the set temperature.

DHW is normally heated by the heat pump of the appliance (see chapter "Specification / Data table").



#### Note

If the appliance has been isolated from the power supply during operation, the compressor will only restart after the pressure inside the refrigerant circuit has been equalised. Pressure compensation can take several minutes.

### WWK 222 H | WWK 302 H: Electric emergency/booster heater

When the temperature in the upper section of the DHW cylinder drops 10 K below the selected set temperature, the appliance automatically switches on the electric emergency/booster heater. When the temperature in the upper section of the DHW cylinder rises 2 K above the selected set temperature, the appliance switches off the electric emergency/booster heater.

### 3.3 Appliance operation outside the application limits

#### 3.3.1 Ambient temperatures below the application limit

Outside the application limits, the appliance disables the compressor operation. This could lead to reduced DHW convenience. If the appliance has an electric emergency/booster heater, this will be enabled if a demand for heating up the water exists and the lower application limit is underrun.

Low ambient temperatures may result in the formation of hoar frost on the evaporator depending on the air humidity and water temperature.

#### Active defrost feature

The appliance is equipped with active hot gas defrosting, which allows quick defrosting of the evaporator when needed. During defrosting, the appliance fan is disabled and the compressor continues to run. A solenoid valve routes the hot gas directly to the evaporator. While this is happening, the condenser is disabled by another solenoid valve.

In contrast to conventional defrosting methods, the appliance guarantees that defrosting takes place only when needed.



#### Note

Heat-up times are longer while the evaporator is defrosting.

#### 3.3.2 Ambient temperatures above the application limit

Outside the application limits, the appliance disables the compressor operation. This could lead to reduced DHW convenience. If the appliance has an electric emergency/booster heater, this will be enabled if a demand for heating up the water exists and the lower application limit is underrun.

### 3.4 Frost protection

The appliance activates the frost protection function if the integral sensor in the DHW cylinder captures a temperature below 10 °C. The appliance then heats the water by means of the heat pump and the electric emergency/booster heater. The heat pump and electric emergency/booster heater switch off when the temperature captured by the integral sensor reaches 18 °C.

**3.5 Minimum runtime and minimum pause time**



**Material losses**

When operating with external switching devices that can interrupt the power supply to the appliance, such as time switches, energy management systems or home automation systems, observe the following conditions:

- The minimum ON time is 60 minutes.
- The minimum pause time following a shutdown is 20 minutes.
- The appliance should not be switched on/off more than 10 times per day.
- The breaking capacity of the switching element must meet the fuse rating requirements (see chapter "Specification / Data table").



**Material losses**

If you disconnect the appliance from the power supply, it is no longer protected against frost.



**Material losses**

At the factory, the appliance is fitted with rechargeable batteries that ensure power supply to the impressed current anode in the case of a power failure.

To enable the impressed current anode to provide protection against corrosion, the power supply to the appliance must not be interrupted for more than 16 hours if the DHW cylinder is filled with water and the anode is not connected separately to a continuous power supply source.

If regular interruptions to the power supply are not anticipated, the batteries will require no maintenance.

Every three years, you must replace the batteries for the impressed current anode in the following cases:

- The impressed current anode is not connected separately to a continuous power supply source and a switching contact regularly interrupts the power supply to the appliance.
- The security of supply is inadequate.

Neglecting to do this puts the appliance at risk of damage. Never use batteries that cannot be charged. Only nickel-metal hydride (Ni-MH) rechargeable batteries are permissible.

Batteries may be damaged in the appliance. Without a power supply, the impressed current anode and the cylinder would not be protected against corrosion.

**3.6 Connection of an external signal transmitter**



**Note**

This type of connection must only be carried out by a qualified electrician.

External signal transmitters can be integrated via the built-in contact input, e.g. a PV system to make use of solar power generated on site.

The appliance has a second set temperature preselected at the factory. This is activated in the event of an external switching signal. Set temperature 2 takes priority over the standard set temperature while there is an external switching signal.

Following a one-off activation (signal is present for at least 1 minute), set temperature 2 applies for at least 20 minutes and is ranked higher than set temperature 1.

The qualified contractor can use software to change set temperature 2 with an accessory available from us.

**4. Settings**

Adjustments are not necessary. The DHW temperature has been set at the factory.

**Emergency shutdown**

In the event of an emergency, carry out the following steps:

- ▶ Disconnect the appliance from the mains at the MCB/fuse in the fuse box.
- ▶ Shut off the cold water supply.

**5. Cleaning, care and maintenance**



**WARNING Electrocutation**

- Only clean the exterior of the appliance.
- Never open the appliance.
- Do not insert objects through the grills into the interior of the appliance.
- Never spray the appliance with water.
- Never spray water into the appliance.



**WARNING Injury**

Maintenance work, such as checking electrical safety, must only be carried out by a qualified contractor.

Appliance components	Care and maintenance tips
Casing	Use a damp cloth to clean the casing sections. Never use abrasive or corrosive cleaning agents.
Air intake grille / air discharge grille	Clean the air intake grille and air discharge grille every six months. Cobwebs or other kinds of contamination could obstruct the air supply to the appliance.
DHW cylinder	The DHW cylinder is equipped with a maintenance-free impressed current anode to safeguard it against corrosion. The power supply must not be interrupted for more than 16 hours while the DHW cylinder is filled with water to enable the impressed current anode to provide protection against corrosion.
Electric emergency/booster heater	Have the electric emergency/booster heater descaled from time to time. This will extend the service life of the electric emergency/booster heater.
Safety equipment	Activate any valves at least once every 6 months to prevent blockages, e.g. by limescale deposits.
Evaporator	Have the evaporator checked regularly by a qualified contractor.
Condensate drain	Undo the condensate drain. Check that the condensate drain is clear and remove any dirt from the condensate drain connection.

## Cleaning, care and maintenance

### Protective anode and battery replacement

The appliance is equipped with a maintenance-free, impressed current anode that protects the tank from corrosion while it is supplied with power. At the factory, the appliance is fitted with rechargeable batteries that ensure the power supply to the impressed current anode in the case of a power failure. The power supply may be interrupted for up to 16 hours.

If the power supply is regularly interrupted by a switching contact or the security of supply is inadequate, the batteries of the impressed current anode must be replaced every three years. Neglecting to do this puts the appliance at risk of damage. If regular interruptions in the power supply are not anticipated and there is security of supply, no maintenance of the batteries is required and the appliance is maintenance-free in this regard.

- ▶ Undo the plug-in connection by pressing the connection lock on both sides.

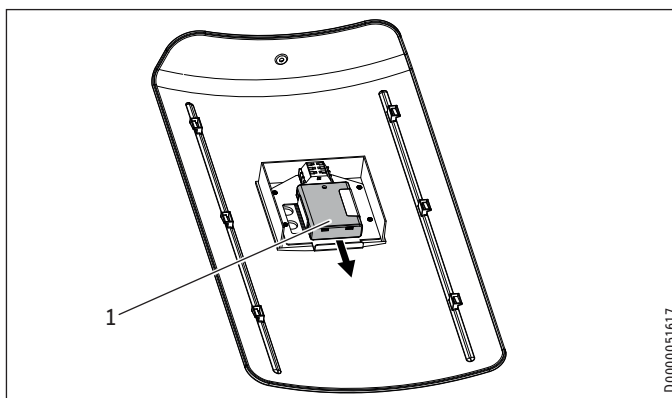

#### 1 Battery compartment

- ▶ Pull the battery compartment down to remove it from the retainer.
- ▶ Open the battery compartment using a screwdriver.
- ▶ Replace the batteries (NiMH, type AAA,  $\geq 800$  mAh).

### ! Material losses

Never use batteries that cannot be charged. Only rechargeable batteries are permissible.

Batteries may be damaged in the appliance. Without a power supply, the impressed current anode and the cylinder would not be protected against corrosion.

The rechargeable batteries are secured at the back of the fascia.

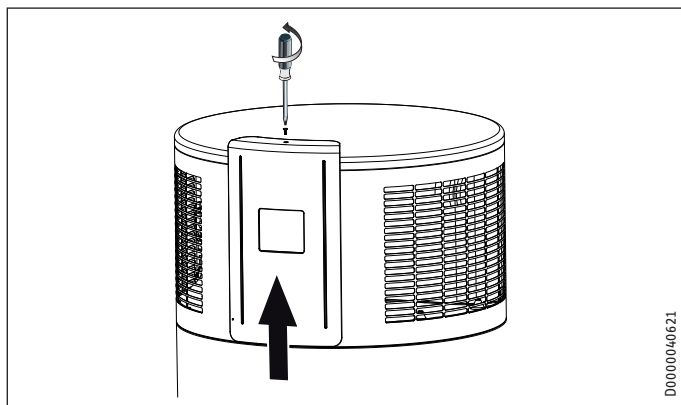

- ▶ Undo the screw securing the fascia.
- ▶ Carefully remove the fascia so that the cables running from the batteries to the impressed current anode in the appliance are not pulled out.

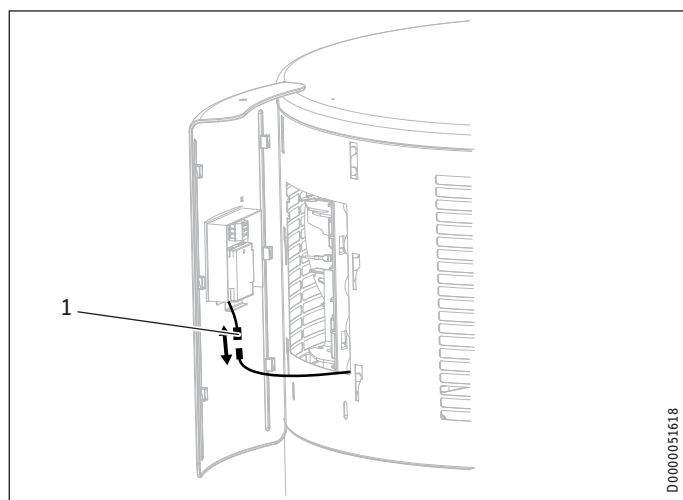

#### 1 Plug-in connection

### ! Material losses

Make sure that the batteries are properly inserted the right way round, because otherwise there will be no corrosion protection in the event of interruptions in the power supply.

- ▶ Close the battery compartment using a screwdriver.
- ▶ Push the battery compartment into the retainer.
- ▶ Reconnect it to the appliance with the plug-in connection.



# OPERATION

## Troubleshooting

### 6. Troubleshooting

Problem	Cause	► Remedy
No hot water is available.	No power at the appliance.	Check that the appliance is connected to the power supply.
	A fuse/MCB in the fuse box has blown/responded.	Check whether the fuses/MCBs in your fuse box have blown/responded. Contact a qualified contractor if the fuse blows or the MCB responds again after the appliance is connected to the power supply.
	The air intake or air discharge of the appliance is blocked.	Check the air intake grille and air discharge grille for contamination. Remove any contamination (see chapter "Maintenance and care").
	Outside the application limits, the appliance blocks the compressor. This could lead to reduced DHW convenience.	No action required. The appliance will then restart the compressor automatically.
	The DHW cylinder is not completely full.	The appliance restarts automatically when the DHW cylinder has been filled.
	Due to a previous high demand for hot water, the unit has not had the chance to fully recover.	No action required. Allow the unit to continue operating normally until the heating cycle is completed.
	The safety pressure limiter has responded 5 times in 5 hours.	Notify a qualified contractor who will reset the safety pressure limiter.
A safety valve is dripping.	These units are under water mains pressure. During the heat-up process, expansion water will drip from a safety valve.	If water continues to drip when heating is completed, please inform your qualified contractor.
The condensate drain drips.	The surface temperature of the evaporator is lower than the dew point temperature of the ambient air. Condensate forms.	This is expected and no action is required. The amount of condensate depends on the air humidity level.
For indoor installations the room temperature drops too low.		Operation of the appliance can cause the room temperature to fall by 1 to 3 °C. If the room temperature falls by more than 5 °C, check the room size (see chapter "Specification / Data table"). Increasing the room size by opening a door to another room will remedy this.

### Notifying a qualified contractor

If you cannot remedy the fault, notify your qualified contractor. In Australia direct notify us (1800153351). To facilitate and speed up your request, provide the number from the type plate (000000-0000-000000). The type plate can be found on the left, above the DHW outlet connection.

### Sample type plate

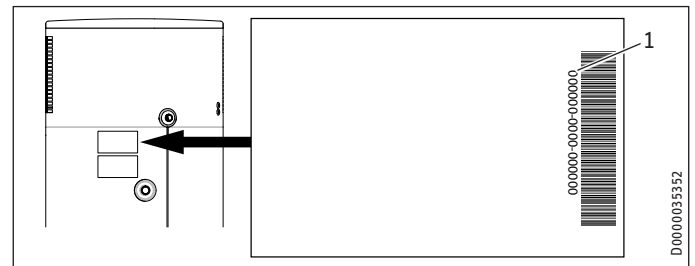

1 Number on the type plate

# INSTALLATION

## 7. Safety

Only a qualified contractor should carry out installation, commissioning, maintenance and repair of the appliance.

### 7.1 General safety instructions

We guarantee trouble-free function and operational reliability only if original accessories and spare parts intended for the appliance are used.

### 7.2 Instructions, standards and regulations



#### Note

Observe all applicable national and regional regulations and instructions.

Take note of the appliance type plate and chapter "Specification".

## 8. Appliance description

The heat pump drive unit is located in the upper section of the appliance. The DHW cylinder is located in the lower section of the appliance.

### 8.1 Standard delivery

The following are delivered with the appliance:

- Condensate drain bend
- 2 straight pipe adapters G1 to G3/4 (use subject to type of installation, see chapter "Preparations / Siting the appliance / Minimum clearances") comprising a flanged pipe, a gasket and a union nut
- 2 135° pipe adapters G1 to G3/4 union nut (use subject to type of installation, see chapter "Preparations / Siting the appliance / Minimum clearances")

### 8.2 Required accessories

Various safety assemblies are available that need to be selected subject to the static pressure. These type-tested safety assemblies protect the appliance against unacceptable excess pressure.

### 8.3 Further accessories

- Condensate pump (if the condensate cannot be drained off with a naturally occurring fall)

### 8.4 Incorrect use

The following are not permitted:

- Operating the appliance when the casing is open
- Filling the appliance with a refrigerant other than the one detailed in chapter "Specification / Data table"
- Heating liquids other than potable water

Observe the list of requirements regarding the installation room and non-permissible installation sites (see chapter "Installation site").

## 9. Preparations

### 9.1 Transport



#### CAUTION Injury

- ▶ Observe the weight of the appliance.
- ▶ Use suitable transport aids (e.g. a pallet trolley) and enough personnel for transportation.



#### Material losses

- The appliance has a high centre of gravity and low overturning moment.
- ▶ Safeguard the appliance against falling over.
  - ▶ Only set the appliance down on an even base.



#### Material losses

- The appliance casing is not designed to withstand strong forces. Incorrect handling can lead to material losses of considerable extent.
- ▶ Observe the information on the packaging.
- Only remove the packaging shortly before the installation.

Where possible, do not unpack the appliance until it has arrived in the installation room.

For transport and handling leave the appliance in its packaging and on the pallet. This enables brief horizontal transport and provides places to hold on to during transport.

If the appliance has to be unpacked before transportation, we recommend using a pallet trolley. Pad the contact surfaces to avoid damaging the appliance. Secure the appliance to the pallet trolley using a strap. Pad between the strap and the appliance and avoid overtightening the strap. Where stair wells are narrow, you can carry the appliance by the handles on the pallet trolley and the foot of the appliance.

#### Vehicular transport



#### Material losses

- The appliance must generally be stored and transported vertically.

A transport lock fitted at the factory to the refrigerant circuit area inside the appliance enables relatively short transportation horizontally over a maximum distance of 160 km of paved roads. Strong shocks are not permissible.



#### Material losses

- If transported horizontally, the appliance must always be laid on the shaded side of the box.
- The appliance must not remain in a horizontal position for more than 24 hours.
- If the appliance was transported horizontally, leave it to rest in a vertical position for at least one hour before commissioning.

- ▶ Observe the information on the packaging.

# INSTALLATION

## Preparations

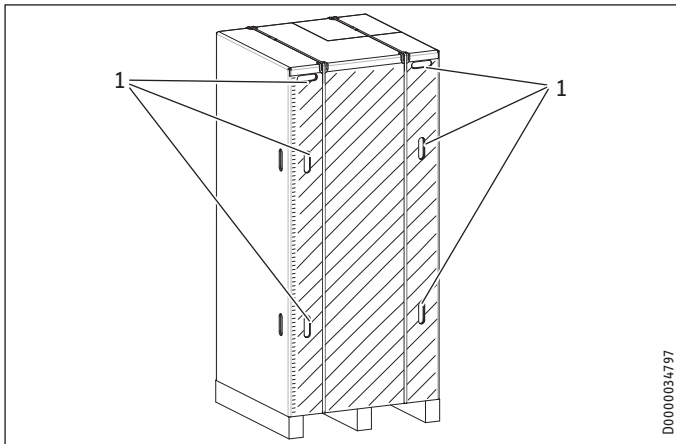

1 Recessed grips

### Transport from vehicle to installation room

The cardboard box has reinforced handholds (recessed grips). You can use these recessed grips, as well as the pallet at the lower end, to carry the appliance into the installation room. Take note of the weight of the appliance and ensure a sufficient number of personnel is available for handling the appliance.

### 9.2 Storage

If it is necessary to store the appliance for a prolonged period before installation, observe the following information:

- Only store the appliance in a vertical position. Never store the appliance horizontally.
- Store the appliance in a location that is dry and largely dust-free.
- Protect the appliance from coming into contact with corrosive substances.
- Ensure the appliance is not subjected to shocks or vibrations.

### 9.3 Installation site



#### Material losses

Observe the following list of requirements regarding the installation site.

- Install the appliance where it will be as little exposed to strong direct wind, extrem rain, sun or snow as possible, but will still be well ventilated. Unhindered air intake and air discharge should be possible. If necessary, protect the appliance against the elements with a canopy, base and deflectors.
- The installation site must be free from flammable, highly combustible gases and substances, as well as high levels of dust.
- The application limits for the heat pump and DHW cylinder must be maintained (see chapter "Specification / Data table").
- The substrate of the installation site must be level and have sufficient load bearing capacity. Take note of the weight of the appliance with a full DHW cylinder (see chapter "Specification / Data table"). A floor with insufficient load bearing capacity is in danger of collapse. If the appliance is not level, there may be a risk of appliance damage.

- In the case of indoor installation, the size of the installation room must correspond to the application limits of the appliance (see chapter "Specification / Data table").
- Observe the safety clearances and protection zones.
- Always leave sufficient space to provide access for installation, maintenance and cleaning. Observe the minimum clearances (see "Preparations / Siting the appliance").
- Ensure the operation of other equipment in the installation room is not impaired.
- To keep the length of the water pipes as short as possible, we recommend installing the appliance close to the kitchen or bathrooms.
- To prevent adverse effects from operating noise, never install the appliance close to bedrooms.



#### Material losses

- Never install or draw off supply air from locations with aggressive atmospheres. This may damage the appliance.
- ▶ Check the wider environment around the planned installation site. Check for anything which may have adverse effects on the installation site or the air supply.

#### Examples of unacceptable installations

Atmospheres containing ammonia	sewage works, pigsties
Substances which block the evaporator	Air containing oil or fat, dust (cement, flour, etc.). Note: If the air contains hairspray (e.g. in hairdressing salons) the appliance should only be operated with reduced maintenance intervals.
Saline atmospheres	Coastal installations (< 200 m from coast line) may reduce the life of components.
atmospheres containing chlorine or chloride	swimming pools, salt works
atmospheres containing thermal water	
Areas in proximity to high frequency machines	inverters for large motors, radar, etc.

If the air contains hairspray (e.g. in hairdressing salons), the appliance should only be operated with reduced maintenance intervals.



#### Note

The output data given for this appliance has been determined in accordance with the relevant standard at an intake temperature of 15 °C. Below 15 °C, the efficiency of the appliance decreases.



#### Note

You can improve the efficiency of the appliance by utilising the waste heat from other appliances to heat the DHW cylinder, e.g. boilers, tumble dryers or freezers.

#### Sound emissions

The sound emissions are louder on the air intake and air discharge sides of the appliance than on the closed sides.

- ▶ Never direct the air intake or air discharge towards noise-sensitive rooms of the house, e.g. bedrooms.

# INSTALLATION

## Preparations



**Note**  
For details on sounds emissions, see chapter "Specification / Data table".

### 9.4 Siting the appliance

- ▶ Carefully undo the cardboard packaging at the clips.

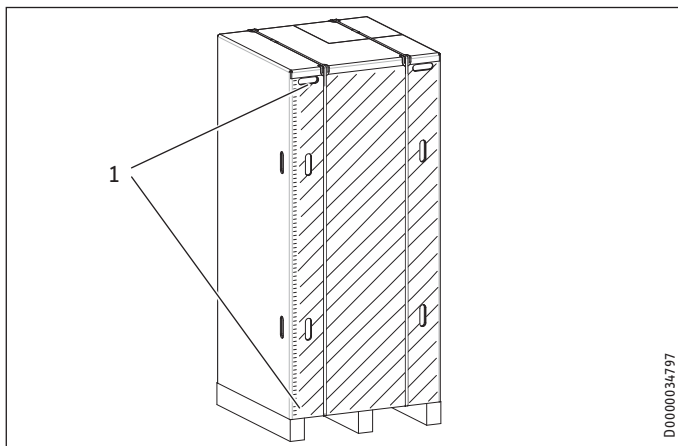

#### 1 Cardboard packaging clips

The appliance is secured to the pallet with metal brackets and screws. The metal brackets are hooked on to the feet underneath the floor plate of the appliance.

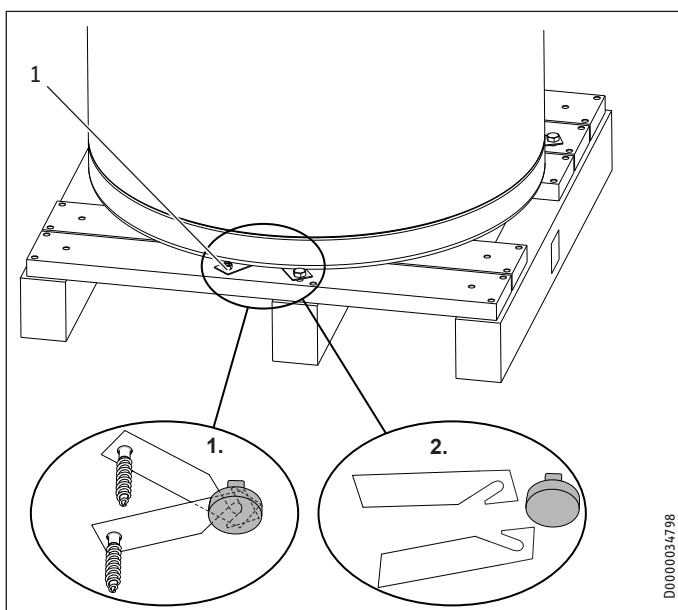

#### 1 Metal bracket fixing screw

- ▶ Remove the fixing screws of the metal brackets from the pallet.
- ▶ Push the metal brackets a little towards the cylinder centre to unhook them from the appliance feet.
- ▶ Pull the metal brackets out from underneath the appliance.



**Material losses**  
Take note of the appliance's weight and centre of gravity.

- ▶ Slightly tip the appliance and carefully roll the appliance off the pallet.
- ▶ Position the appliance in the final installation site.



**Material losses**  
The appliance must be positioned vertically to avoid damage.  
The feet under the floor plate of the appliance are height-adjustable.  
▶ Level the appliance horizontally using the height-adjustable feet.

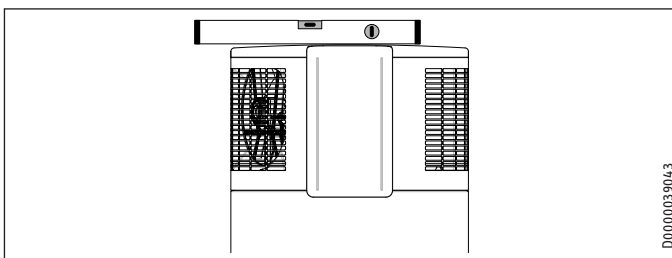

#### 9.4.1 Minimum clearances

- ▶ Maintain the minimum clearances.

#### Connecting with straight pipe adapters

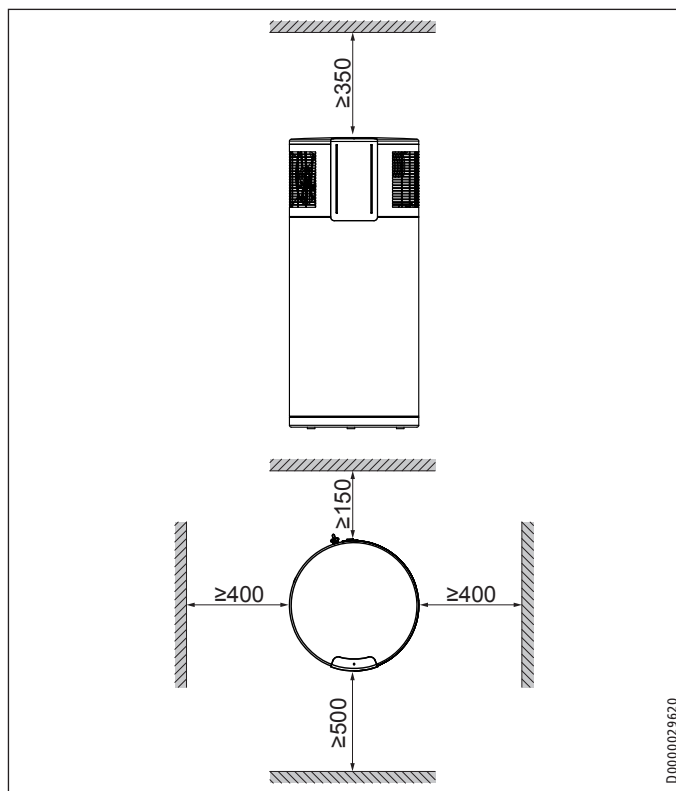

**Note**  
If you install the supplied bracket pipe adapters on the "Cold water inlet" and "DHW outlet" connections, you can reduce the minimum clearance at the back of the appliance described in the following installation.

# INSTALLATION

## Installation

### Connecting with bracket pipe adapters (mainly in Australia)

With these options, the "Cold water inlet" and "DHW outlet" connections are located on the right hand side or on the left behind the appliance.

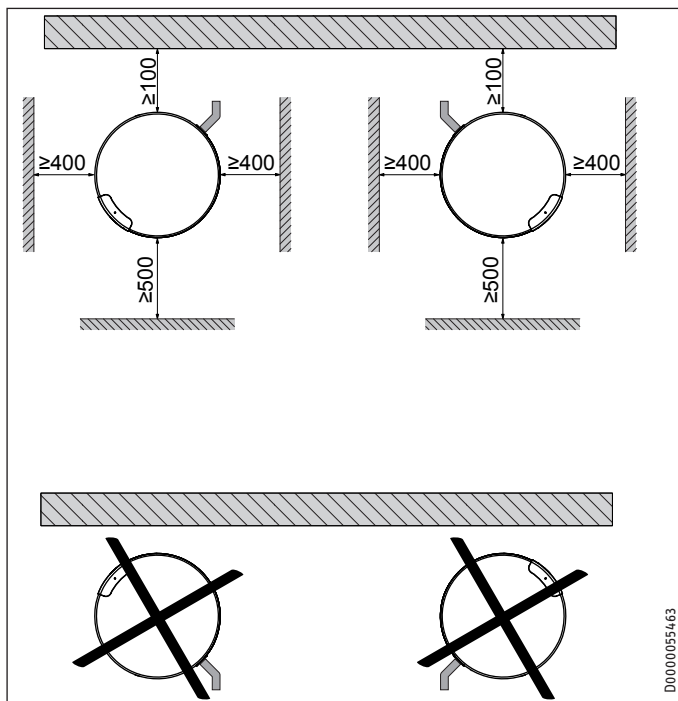

## 10. Installation



**WARNING Injury**  
 Incorrect installation can lead to serious injury or material losses.  
 Before any work, ensure sufficient clearances for the installation.  
 Handle sharp-edged components carefully.

### 10.1 Water connection



**Material losses**  
 Carry out all water connection and installation work in accordance with regulations.



**Material losses**  
 The cathodic corrosion protection can only be guaranteed when the electrical conductivity of the domestic hot water is within the limits stated in the chapter "Specification / Data table".

The following material combinations are approved for metal pipework installations:

Cold water inlet	DHW outlet
Copper pipe	Copper pipe
Steel pipe	Steel pipe or copper pipe

- ▶ Thoroughly flush the pipework before connecting the appliance. Foreign bodies, such as plastic and metal shavings, rust, sand or sealant can impair the operational reliability of the appliance.



**Material losses**  
 To protect the connections against corrosion the water connection must be made with flat gaskets. The use of hemp on connections is not permissible.

- ▶ Install the DHW outlet line and the cold water inlet line (see chapter "Specification / Dimensions and connections").

#### 10.1.1 Safety equipment

A T&P valve or a safety valve (cold water expansion control valve) has to be installed. Observe all applicable national and regional regulations and instructions.

##### T&P valve (700 kPa)

- ▶ If specified, install a type-tested T&P valve using the corresponding connection on the appliance.

The response pressure of the valve must be below or equal to the permissible operating pressure of the DHW cylinder. The valve protects the appliance against unacceptable pressure or temperature rises. The diameter of the cold water supply line must be no greater than the diameter of the valve.

- ▶ Ensure that the expansion water escaping from the valve can drip into a drain, e.g. a tundish.

Ensure the drain cannot be shut off.

- ▶ Size the drain so that water can drain off unimpeded when the safety valve is fully opened.
- ▶ Ensure that the discharge pipe of the safety valve is open to atmosphere.
- ▶ Fit the discharge pipe of the safety valve with a constant downward slope and in a location free from the risk of frost.

# INSTALLATION

## Installation

### Safety valve (cold water expansion control valve, 550 kPa)

- ▶ If specified, install a type-tested 550 kPa safety valve (expansion control valve) in the cold water supply line.

The safety valve protects the appliance against unacceptable excess pressure. The diameter of the cold water supply line must be no greater than the diameter of the safety valve.

- ▶ Ensure that the expansion water escaping from the safety valve can drip into a drain, e.g. a tank or funnel.

Ensure the drain cannot be shut off.

- ▶ Size the drain so that water can drain off unimpeded when the safety valve is fully opened.
- ▶ Ensure that the discharge pipe of the safety valve is open to atmosphere.
- ▶ Fit the discharge pipe of the safety valve with a constant downward slope and in a room free from the risk of frost.

### 10.1.2 Pressure reducing valve

The maximum pressure in the cold water supply line must be at least 20 % below the response pressure of the lowest pressure rated valve installed, otherwise a pressure reduction valve will be required. If this is the case, install a pressure reduction valve in the cold water feed. The pressure reducing valve must be set to 440 kPa if a safety valve is installed; otherwise to 550 kPa.

### 10.1.3 Drain valve

- ▶ Install a suitable drain valve at the lowest point in the cold water inlet line.

### 10.1.4 Thermal insulation

- ▶ Insulate the DHW line and valves against heat loss and to improve energy efficiency in accordance with locally applicable regulations.
- ▶ Insulate the cold water supply line to prevent condensate forming.

### 10.1.5 DHW outlet



#### WARNING Burns

The water in the DHW cylinder can be heated to temperatures in excess of 60 °C. There is a risk of scalding at outlet temperatures in excess of 43 °C.

In Australia and New Zealand, observe regulations in accordance with AS/NZS3500.4:

- ▶ Install a tempering device in all systems intended for personal hygiene.

## 10.2 Condensate drain

Install a condensate drain hose in order to remove the condensate which forms.

- ▶ Connect the condensate drain bend included in the standard delivery to the condensate drain connection.
- ▶ Connect a condensate drain hose to the condensate drain bend.



### Material losses

Ensure condensate cannot back up.

- ▶ Use a condensate drain hose with a diameter greater than the diameter of the condensate drain bend.
- ▶ Ensure the condensate drain hose is not kinked.
- ▶ Route the condensate drain hose with a continuous fall.

The condensate drain must be open to atmosphere.

- ▶ Use a suitable condensate pump if there is insufficient fall. Observe the building characteristics.

## Condensate pan heater



### Material losses

If the temperature at the installation site could continuously fall below freezing (1 - 2 days) you should install a condensate pan heater. The condensate pan heater is not part of the standard delivery.

When the compressor is running, install a load-dependent relay to switch on the condensate pan heater after a delay.

The condensate pan heater must have an external power supply.

## 10.3 Power supply



### WARNING Electrocutation

The connection to the power supply must be in the form of a permanent connection. Ensure the appliance can be separated from the power supply by an isolator that disconnects all poles with at least 3 mm contact separation. Contactors, mains isolators or fuses can be used for this. This type of isolator must be installed in the fixed electrical installation according to the regulations. For Australia: Ensure the appliance can be separated from the power supply by a suitable isolator. Contactors, circuit breakers or fuses can be used for this. This type of isolator must be installed in accordance with the wiring rules.



### WARNING Electrocutation

Carry out all electrical connection and installation work in accordance with national and regional regulations.



### WARNING Electrocutation

Ensure that the appliance is earthed.



### WARNING Electrocutation

Observe the safety measures to prevent contact with dangerous 'live' currents.



### WARNING Electrocutation

Coming into contact with 'live' components presents a threat to life. Disconnect the appliance from the power supply before carrying out work inside the appliance. Prevent the power supply from being switched on while you are working on the system.

# INSTALLATION

## Installation



**WARNING Electrocutation**  
Insufficient earthing can lead to electrocution. Ensure the appliance is earthed according to locally applicable requirements.



**WARNING Electrocutation**  
If the power cable is faulty, replace it with a new one. The power cable should only be replaced by a qualified contractor.



**Material losses**  
The specified voltage must match the mains voltage. Observe the type plate.



**Material losses**  
Observe the MCB/fuse protection required for the appliance (see chapter "Specification / Data table").



**Material losses**  
Never connect the appliance to the power supply before the DHW cylinder is filled.

The appliance is supplied with a flexible power cable without plug.

- ▶ If the power cable is not long enough, unclamp it from the appliance. Use a suitable installation cable.
- ▶ When routing the new power cable, ensure that it is waterproof as it passes through the existing cable grommet. Connect the connecting cable properly inside the appliance.

### 10.3.1 Standard connection (without external signal transmitter)

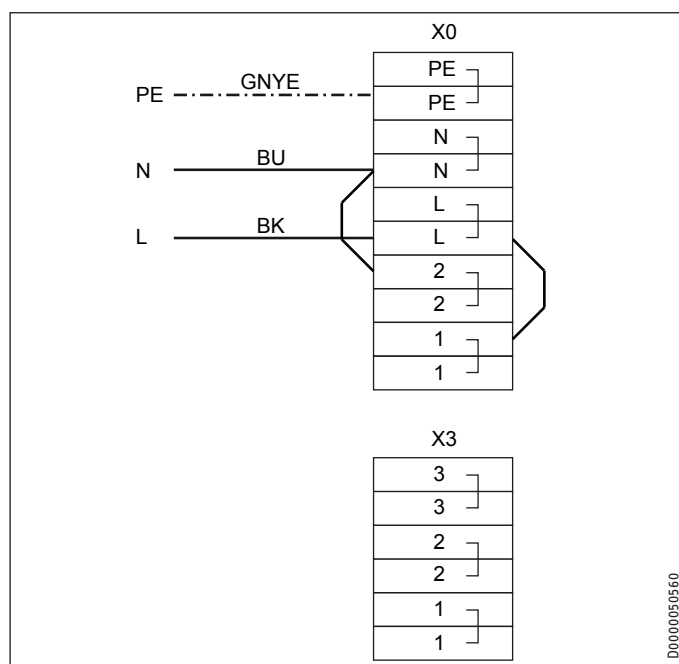

BK black  
BU blue  
GNYE green/yellow

### 10.3.2 Separate power supply to the impressed current anode

At the factory, the appliance is fitted with rechargeable batteries that ensure the power supply to the impressed current anode in the case of a power failure. If regular interruptions to the power supply are not anticipated, the batteries will require no maintenance.

Every three years the batteries must be replaced for the impressed current anode in the following cases:

- The impressed current anode is not connected separately to a continuous power supply source and a switching contact regularly interrupts the power supply to the appliance.
- The security of supply is inadequate.

Neglecting to do this puts the appliance at risk of damage.

Replacing the batteries can be avoided by connecting the impressed current anode separately to a continuous power supply source. This continues to protect the DHW cylinder against corrosion if the rest of the appliance is switched off, e.g. when connected to a controlled power supply.

- ▶ Remove the appliance cover (see chapter "Cleaning and maintenance / Removing the appliance cover").

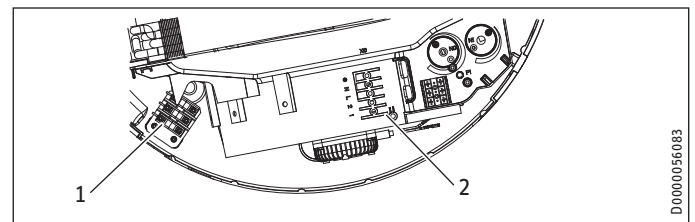

- 1 Strain relief
- 2 Terminal X0

- ▶ Prepare the electric cables in such a way that each cable terminates with a wire ferrule.
- ▶ Push the cables through one of the cable entries in the appliance casing.
- ▶ Route leads through the strain relief.
- ▶ Remove the jumper which leads from X0/N to X0/2 in the delivered condition.
- ▶ Remove the jumper which leads from X0/L to X0/1 in the delivered condition.

# INSTALLATION

## Installation

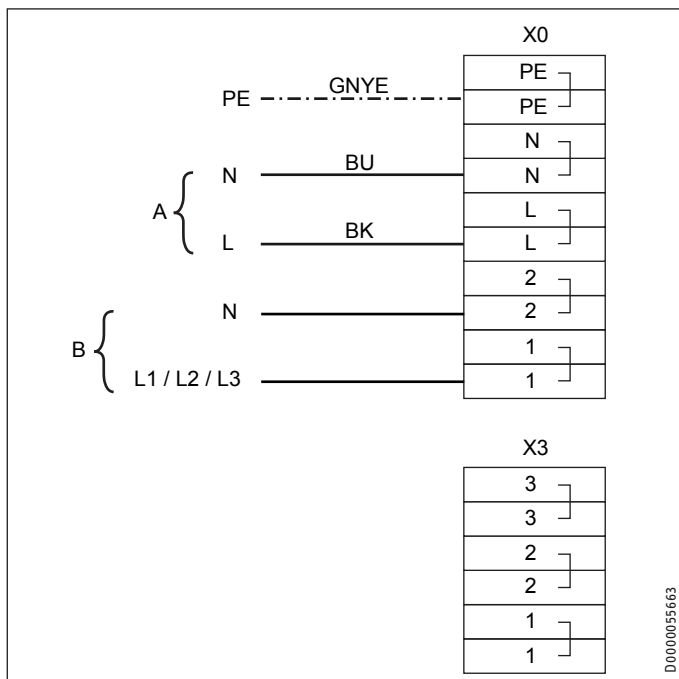

D0000056663

- A Power supply provided by power supply utility or energy management system for switching the load (compressor)
- B Power supply for the impressed current anode and the electronics
- BK black
- BU blue
- GNYE green/yellow
- Connect the electric cables for the separate impressed current anode power supply to X0/1 and X0/2.

### 10.3.3 Connection with external signal transmitter



**Note**

This type of connection must only be carried out by a qualified electrician.



**Note**

The appliance has a second and higher set temperature preselected at the factory. This is activated in the event of an external switching signal. Set temperature 2 takes priority over the standard set temperature while there is an external switching signal.

An external signal transmitter for switching a separate set DHW temperature (set temperature 2) can be connected to terminal X3/1-2. In the delivered condition, terminal X3/1-2 is not assigned. If this terminal is connected at the voltage stated in the specification (see "Permissible voltage range, external signal transducer") (L to X3/1, N to X3/2), the appliance activates set temperature 2.

Following a one-off activation (signal is present for at least 1 minute), set temperature 2 applies for at least 20 minutes. Set temperature 2 is ranked higher than set temperature 1. When the relevant set DHW temperature has been reached, the compressor switches off and remains off for a minimum idle time of 20 minutes.

The following diagram illustrates the connections by means of a sample signal sequence of an external signal transmitter.

Example:

- Water temperature = 61 °C
- Set temperature 1 = 60 °C
- Set temperature 2 = 65 °C

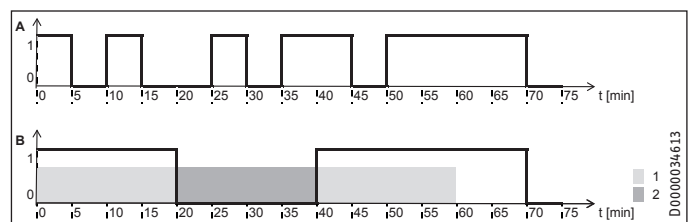

D0000034613

- A External signal
- B Compressor
- 1 20 min. minimum runtime, set temperature 2
- 2 20 min. minimum compressor idle time
- Remove the appliance cover (see chapter "Cleaning and maintenance / Removing the appliance cover").

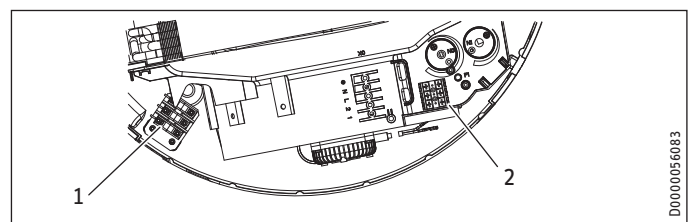

D0000056083

- 1 Strain relief
- 2 Terminal X3
- Prepare the electric cables in such a way that each cable terminates with a wire ferrule.
- Push the cables through one of the cable entries in the appliance casing.



# INSTALLATION

## Installation

- ▶ Route leads through the strain relief.
- ▶ Connect the cables to X3.

### Example 1: Power-OFF signal with its own phase

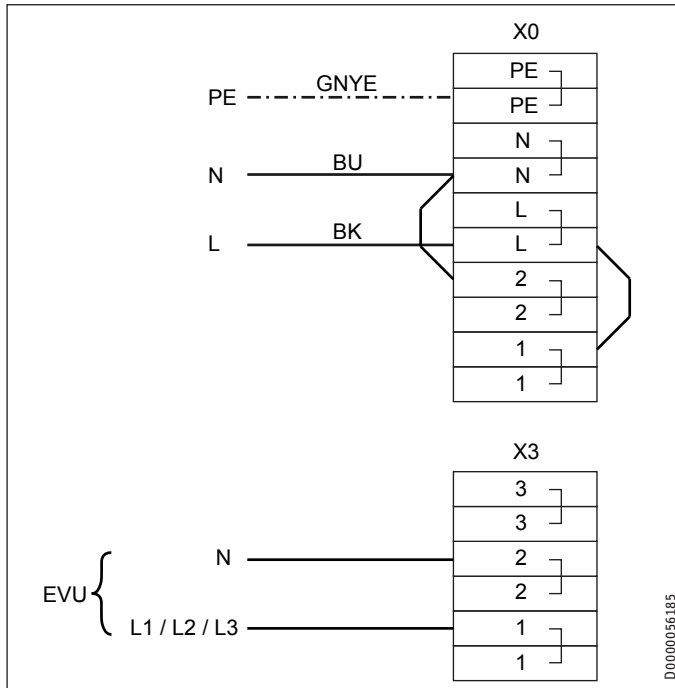

EVU power supply utility  
 BK black  
 BU blue  
 GNYE green/yellow

### Example 2: Photovoltaic signal via on-site relay and phase routed outside the appliance



#### Note

The relay in the inverter must meet the following requirements:

- Potential-free relay (240 V AC / 24 V DC, 1 A) with N/O contact
- Adherence to safety regulations and standards for safety extra low voltage
- The switching output must be programmed so that the relay contact closes or opens if certain limits are exceeded or undershot (inverter output level).

If necessary, check with the inverter manufacturer whether the product meets the stated criteria.

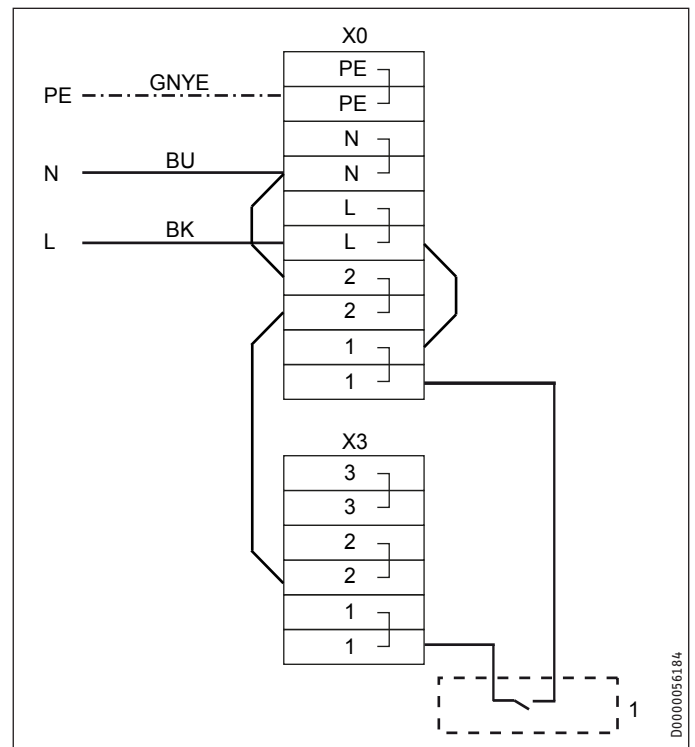

1 Inverter (floating contact)  
 BK black  
 BU blue  
 GNYE green/yellow

The inverter power feed is typically located at a central distribution point (e.g. in the main fuse box).

## 10.4 Assembling the appliance



#### Note

Refit the appliance cover after completing your work. See chapter "Maintenance and cleaning / Fitting the appliance cover".

## 11. Commissioning

### 11.1 Initial start-up



#### Note

Fill the DHW cylinder before switching on the power supply to the appliance.

In case the appliance is energised with an empty DHW cylinder, it is equipped with boil-dry protection that will prevent it from operating.



#### Note

Following an interruption of the power supply, the compressor operation remains blocked for at least one minute, during which the appliance goes through its initialising process.

If the compressor subsequently fails to start, it may be blocked by additional safety devices (motor overload relay, high pressure switch). This block can last from 1 to 10 minutes.

#### 11.1.1 Filling the DHW cylinder

Fill the DHW cylinder and vent the pipework by following the procedure below:

- ▶ Close the drain valve.
- ▶ Open all DHW draw-off points and the shut-off valve in the cold water supply.
- ▶ Close the DHW draw-off points as soon as water starts to emerge from them.
- ▶ Check the safety valve by leaving it open until water runs out.

#### 11.1.2 Settings / function check

In the delivered condition, the appliance is set to a DHW temperature > 60 °C.

- ▶ Switch the mains power ON.



#### Note

Following an interruption of the power supply, the compressor operation remains blocked for at least one minute, during which the appliance goes through its initialising process.

If the compressor subsequently fails to start, it may be blocked by additional safety devices (motor overload relay, high pressure switch). This block can last from 1 to 10 minutes.

- ▶ Check the function of the appliance.
- ▶ Check the function of the safety assembly.

#### 11.1.3 Appliance handover

- ▶ Explain the appliance function to users and familiarise them with its operation.
- ▶ Make the user aware of potential dangers, especially the risk of scalding.
- ▶ Make users aware of critical environmental factors and requirements concerning the installation site.
- ▶ Inform users that water may drip from the safety valve during the heat-up process.
- ▶ Please note that the appliance is not protected against frost and corrosion when it is disconnected from the power supply. At the factory, the appliance is fitted with rechargeable batteries that ensure the power supply to the impressed current anode in the case of a power failure. The batteries must be replaced by a qualified contractor every three years, if the power supply is regularly interrupted by a switching contact or the security of supply is inadequate. A maintenance contract is recommended for replacing the batteries.
- ▶ If the power supply is regularly interrupted by a switching contact or the security of supply is inadequate, we recommend a maintenance contract for replacing the batteries.
- ▶ Hand over these operating and installation instructions to users for safe-keeping.

### 11.2 Recommissioning



#### Note

Following an interruption of the power supply, the compressor operation remains blocked for at least one minute. The PCB delays electronic starting by a minute, during which the appliance goes through its initialising process.

If the compressor subsequently fails to start, it may be blocked by additional safety devices (motor overload relay and high pressure switch). This block can last from 1 to 10 minutes.

If the appliance is switched off due to an interruption to the power supply, no specific measures for restarting are required once the power supply has been restored.

## 12. Shutdown



#### Material losses

If you disconnect the appliance from the power supply, it is no longer protected against frost or corrosion.

- ▶ Only disconnect the appliance from the power supply for longer periods if you are also draining the DHW cylinder. See chapter "Maintenance / Draining the appliance".

The appliance can only be switched off by interrupting the power supply.

- ▶ Disconnect the appliance from the mains at the MCB/fuse in the fuse box.

### 13. Troubleshooting



**WARNING Electrocutation**  
 Troubleshooting work must only be carried out by a qualified contractor. Prior to all work on the appliance, isolate it from the power supply.



**Material losses**  
 If you disconnect the appliance from the power supply, it is no longer protected against frost or corrosion.  
 ► Only disconnect the appliance from the power supply for longer periods if you are also draining the DHW cylinder.

- For work inside the appliance, remove the appliance cover (see chapter "Cleaning and maintenance / Removing the appliance cover").
- If necessary, remove the upper section of the casing jacket (see chapter "Maintenance and cleaning / Removing the casing ring").



**Note**  
 Refit the casing ring after completing the work. See chapter "Maintenance and cleaning / Fitting the casing ring").



**Note**  
 Refit the appliance cover after completing your work. See chapter "Maintenance and cleaning / Fitting the appliance cover").

Fault	Cause	► Remedy
No hot water is available.	The impressed current anode is faulty.	Replace the impressed current anode.
The compressor switches off unexpectedly.	The application limits have been exceeded or undershot.	No action required.
	Excessive pressure in the refrigerant circuit. The safety pressure limiter has responded 5 times in 5 hours. The compressor has been switched off.	Eliminate the cause of the increase in pressure in the refrigerant circuit. Wait approx. 5-15 minutes for the appliance to equalise the pressure. The appliance can only be unblocked using a service programming unit.
The heating output of the appliance has reduced.	An inadequate air flow across the evaporator is a possible cause.	Check whether the fan is contaminated. Check whether the evaporator is contaminated. Ensure that the supply and extract air flow are unimpeded.

#### 13.1 Resetting the safety pressure limiter

The safety pressure limiter shuts down if the pressure inside the refrigerant circuit exceeds the permissible maximum value. If the safety pressure limiter responds 5 times in 5 hours, the compressor operation will be blocked.

- Eliminate the cause of the increase in pressure in the refrigerant circuit
- Wait approx. 5-15 minutes for the appliance to equalise the pressure.

The appliance can only be unblocked using a service programming unit.

#### 13.2 Resetting the high limit safety cut-out (only WWK H)

If the DHW cylinder is overheated, the high limit safety cut-out switches off the electric emergency/booster heater to protect the appliance.

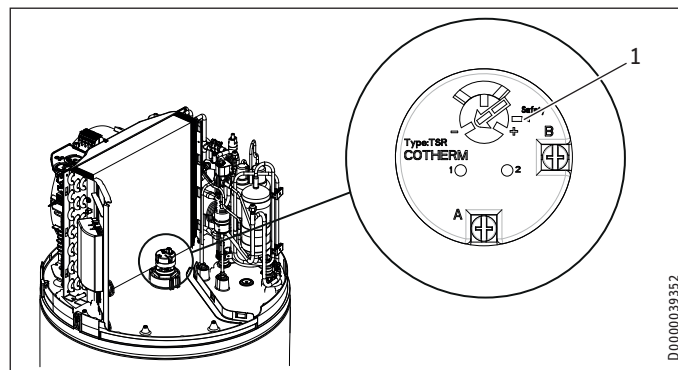

- 1 Reset button for high limit safety cut-out
- Once the cause of the fault has been removed, press the reset button of the high limit safety cut-out on the rod thermostat. To do so, remove the appliance cover.

#### 13.3 Motor overload relay

The motor overload relay will shut down the compressor in the case of excessive thermal load.

- Remove the cause.

After a short cooling period, the motor overload relay will restart the compressor automatically.

### 14. Maintenance



**WARNING Electrocutation**  
Prior to all work on the appliance, isolate it from the power supply.

#### 14.1 Removing the appliance cover

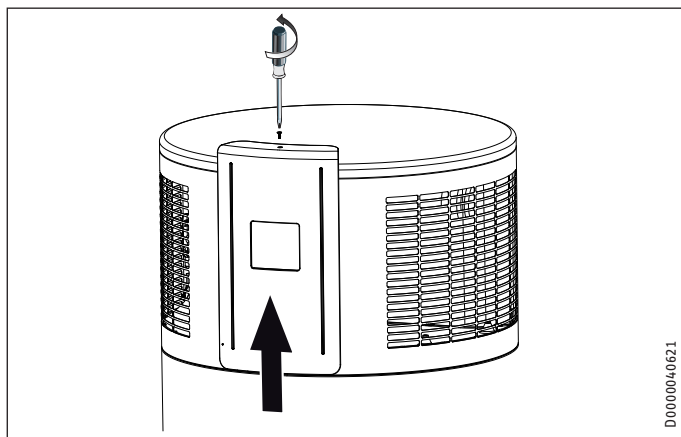

- ▶ Undo the screw (Torx) that attaches the fascia to the appliance.
- ▶ Push the fascia upwards.

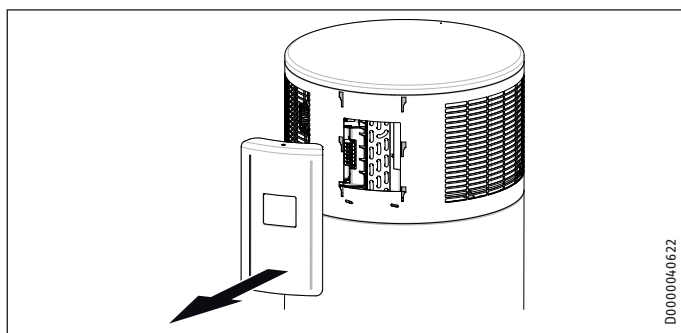

- ▶ Carefully remove the fascia.
- ▶ Undo the plug-in connection in the electrical cable that runs to the battery pack on the back of the fascia.
- ▶ Carefully lift away the appliance cover and undo the earth cable that runs from the terminal strip to the cover.



**Note**  
Refit the appliance cover after completing your work. See chapter "Maintenance and cleaning / Fitting the appliance cover".

#### 14.2 Removing the casing ring



**Note**  
If you require more space to work inside the appliance, you can remove the casing ring on the upper section of the appliance.

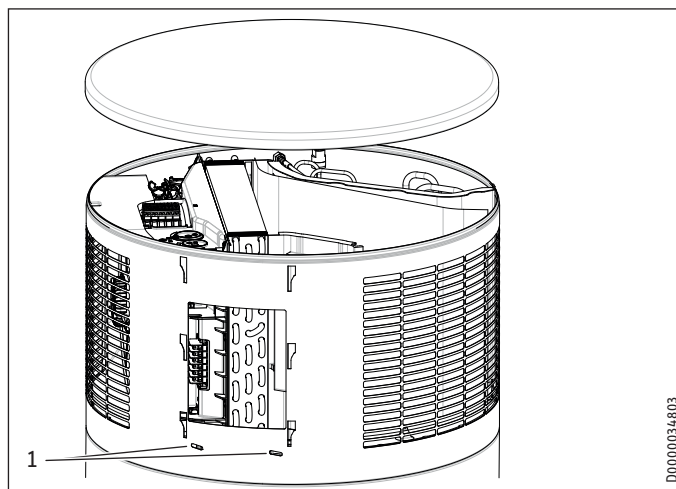

- 1 Fixing screws on casing ring

The casing ring is fastened with screws.

- ▶ Undo the fixing screws on the casing ring.
- ▶ Remove the condensate drain bend and pipe collar of the drain. Turn anti-clockwise to undo them.



#### Material losses

Inside the appliance, an earth cable is connected to the casing ring. Undo the earth cable in order to be able to remove the casing ring.

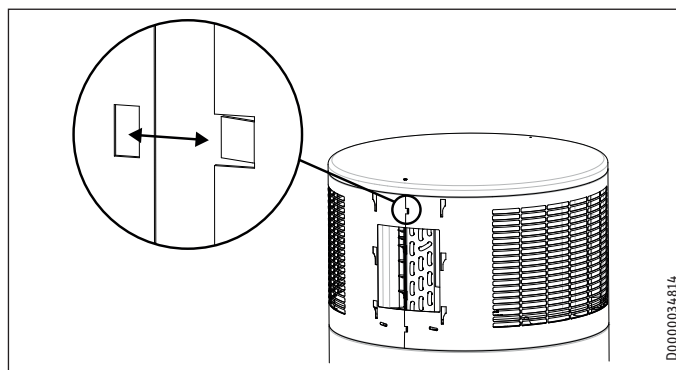

The casing ring overlaps along the joint. A tab on one end clips into the recess at the other end of the casing ring.

- ▶ Ease the casing ring apart, until it can be removed or slid downwards.



**Note**  
Refit the casing ring after completing the work. See chapter "Maintenance and cleaning / Fitting the casing ring".

#### 14.3 Cleaning the evaporator



#### WARNING Injury

The evaporator consists of numerous sharp-edged fins.  
▶ Be careful when cleaning the evaporator and wear protective clothing, especially safety gloves.

In order to maintain the appliance performance at its best, check and clean the appliance evaporator as often as necessary.

# INSTALLATION

## Maintenance

- ▶ Undo the screw that fastens the appliance cover to the top of the fascia.
- ▶ Remove the fascia and the appliance cover.
- ▶ Carefully clean the evaporator fins. Only use water and a soft brush for this. Never use acidic or alkaline cleaning agents.

### 14.4 Draining the cylinder



**WARNING Burns**  
Hot water may escape when draining the DHW cylinder.

To drain the DHW cylinder, e.g. when shutting the appliance down, proceed as follows.

- ▶ Isolate the appliance from the power supply.
- ▶ Close the shut-off valve in the cold water inlet line.

The DHW cylinder is drained via the cold water supply line.

- ▶ Open the drain valve installed in the cold water supply line (see chapter "Water connection"). If no drain valve has been installed, undo the cold water supply line at the "Cold water inlet" connection.
- ▶ To vent the system, undo the DHW line connected to the "DHW outlet" connection.

Some residual water will remain in the bottom of the DHW cylinder.

### 14.5 Descaling the electric emergency/booster heater

Only descale the flange of the emergency/booster heater after disassembly. Never treat the inside of the DHW cylinder or the impressed current anode with descaling agents. The electric emergency/booster heater is screwed into the DHW cylinder of the appliance at a central point at the top.

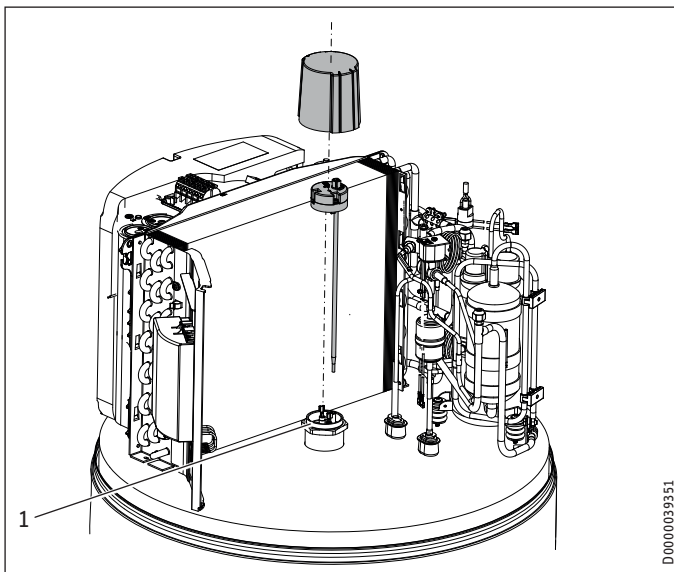

1 Electric emergency/booster heater with protective anode

### 14.6 Valves

Regularly check all valves in the system and replace if necessary to ensure the operational reliability of the appliance. The amount of limescale deposits depends on the local water quality.

- ▶ Check all valves in the system and remove limescale deposits.
- ▶ Replace the valves if necessary.
- ▶ Check the function of the valves.

### 14.7 Condensate drain

- ▶ Check whether the condensate drain is clear of obstructions. Remove contaminants.

### 14.8 Replacing the power cable



**WARNING Electrocution**  
The power cable must only be replaced (for example if damaged) by a qualified contractor.

### 14.9 Fitting the casing ring



**WARNING Electrocution**  
▶ Reconnect the earth cable to the casing ring.

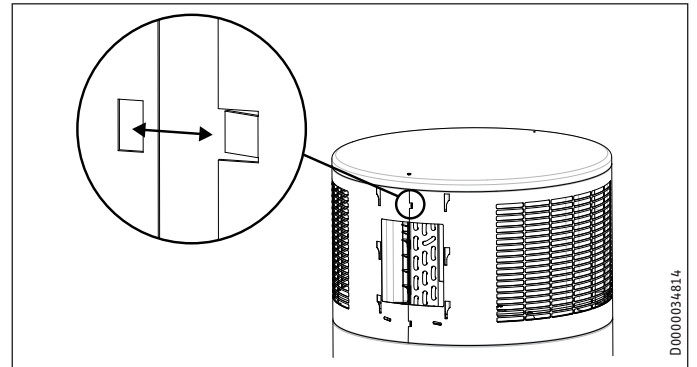

- ▶ Fit the upper casing ring. The casing ring overlaps along the joint. A tab on one end clips into the recess at the other end of the casing ring.
- ▶ Secure the casing ring with screws.
- ▶ Fit the pipe collar of the condensate drain and the condensate drain bend.

### 14.10 Fitting the appliance cover



**WARNING Electrocution**  
▶ Reconnect the earth cable to the appliance cover.

- ▶ Place the cover back on the appliance.
- ▶ Connect the cable linking the batteries with the internal control unit to the back of the fascia.
- ▶ Replace the fascia.
- ▶ Secure the appliance cover and the fascia with the screw at the top of the control fascia.

# INSTALLATION Specification

## 15. Specification

### 15.1 Dimensions and connections

#### 15.1.1 WWK 222 / WWK 222 H

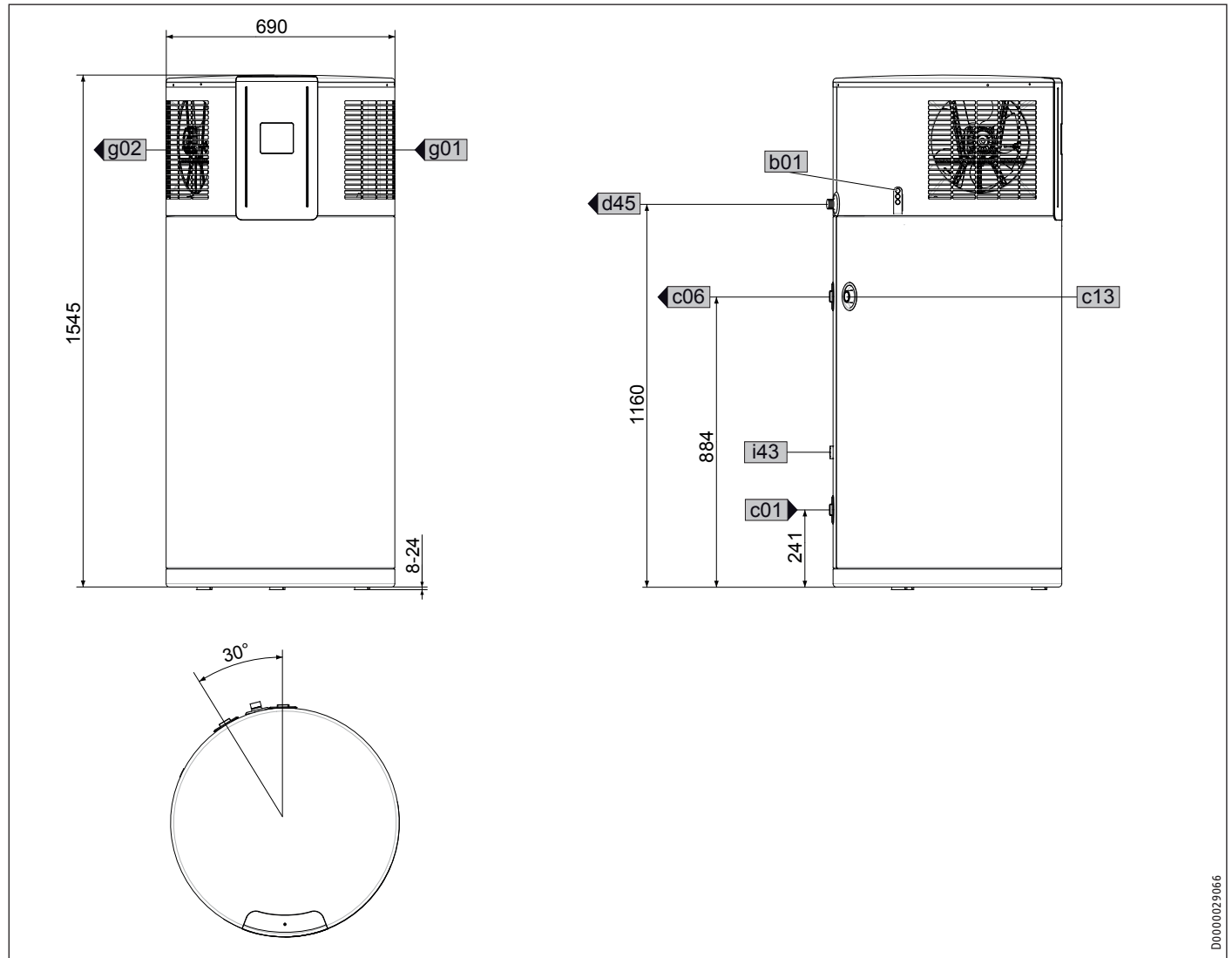

D0000029066

		WWK 222	WWK 222 H
b01	Entry electrical cables		
c01	Cold water inlet	Male thread	G 1
c06	DHW outlet	Male thread	G 1
c13	T&P valve	Female thread	Rp 3/4
d45	Condensate drain	Male thread	G 3/4
g01	Air intake		
g02	Air discharge		
i43	Cover for manufacturing aperture		

# INSTALLATION Specification

## 15.1.2 WWK 302 / WWK 302 H

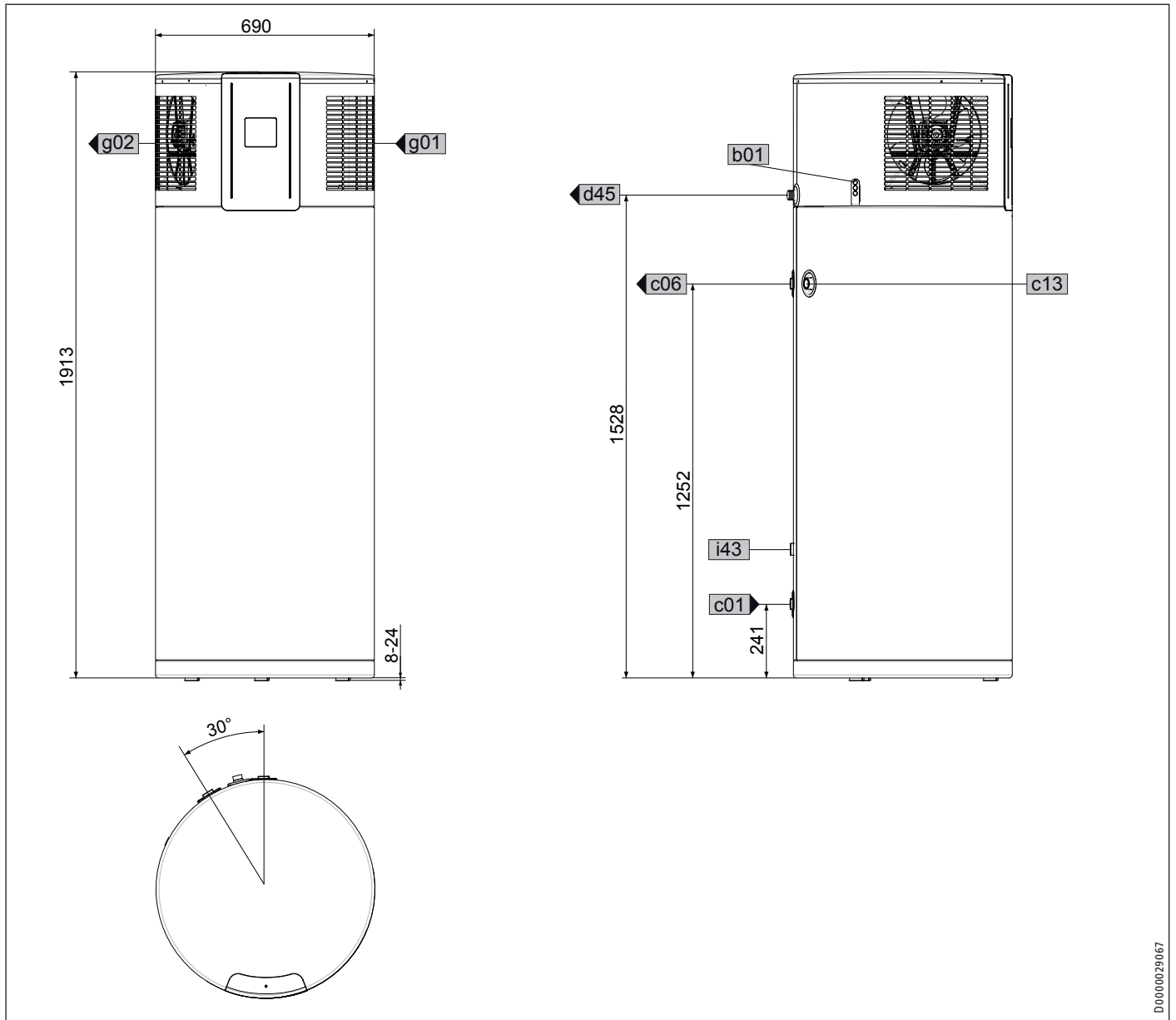

D0000029067

		WWK 302	WWK 302 H
b01	Entry electrical cables		
c01	Cold water inlet	Male thread G 1	G 1
c06	DHW outlet	Male thread G 1	G 1
c13	T&P valve	Female thread Rp 3/4	Rp 3/4
d45	Condensate drain	Male thread G 3/4	G 3/4
g01	Air intake		
g02	Air discharge		
i43	Cover for manufacturing aperture		

# INSTALLATION Specification

## 15.2 Wiring diagram

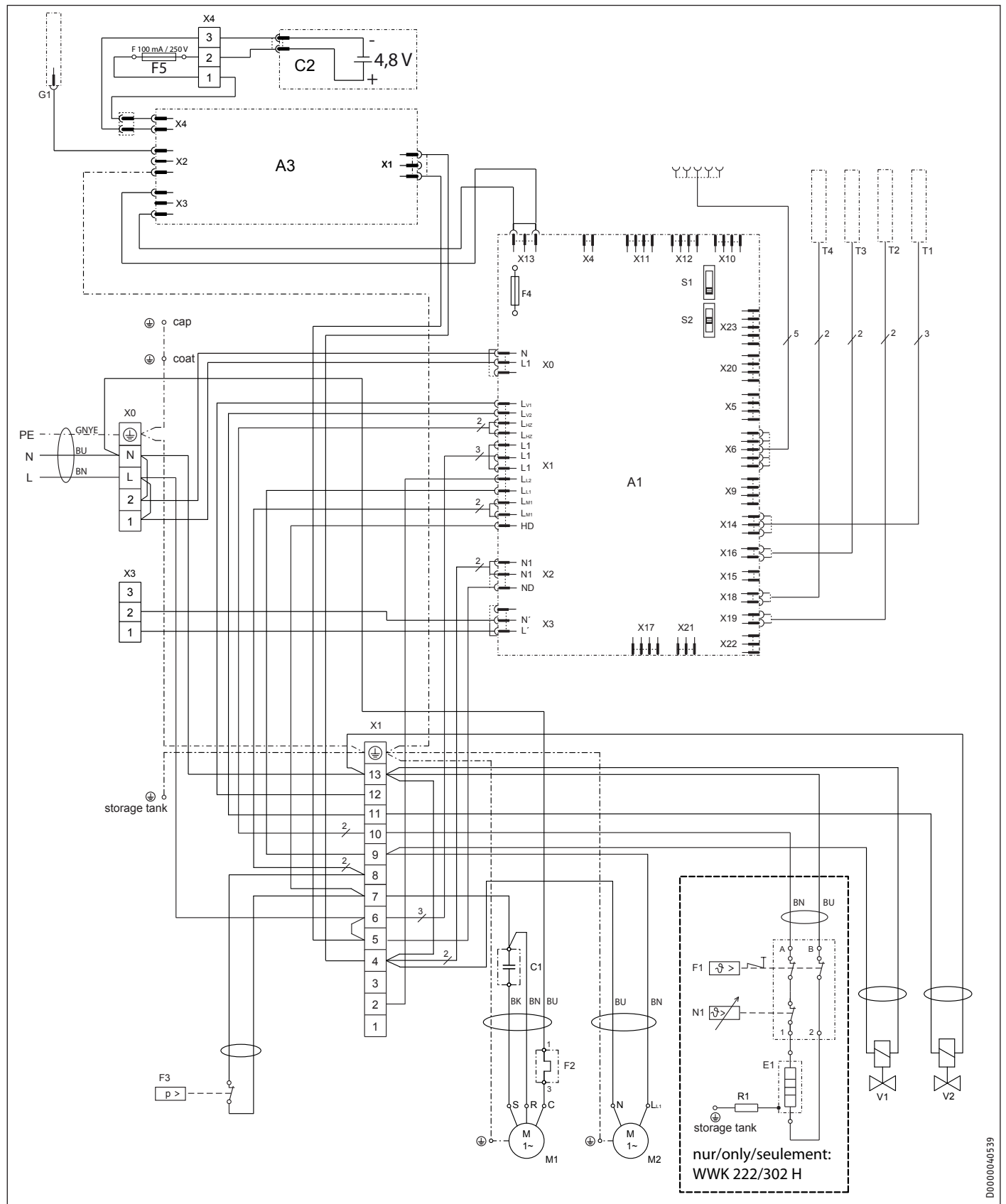

D0000040539



---

## INSTALLATION

# Specification

---

A1	Electronic assembly (control unit)	N1	Thermostat TSR
A3	Electronic assembly (electrical corrosion protection)	R1	Resistance
C1	Run capacitor	S1	DIP switch (operating mode)
C2	Rechargable battery pack	S2	DIP switch
E1	Heating element	T1	Cylinder top/integral temperature sensors
F1	High limit safety cut-out TSR	T2	Temperature sensor, hot gas
F2	Motor overload relay M1	T3	Temperature sensor, air intake
F3	High pressure switch	T4	Temperature sensor,
F4	Fuse	V1	Solenoid valve ('live' in heating mode)
F5	Fuse, power supply, battery	V2	Solenoid valve ('live' in defrost mode)
G1	Impressed current anode	X0	Mains terminal
M1	Compressor	X1	Terminal
M2	Fan	X3	Terminal
		X4	Terminal rechargable battery pack

# INSTALLATION Specification

## 15.3 Data table

		WWK 222	WWK 222 H	WWK 302	WWK 302 H
		231209	233209	231211	232905
<b>Hydraulic data</b>					
Nominal capacity	l	220	220	302	302
<b>Application limits</b>					
DHW temperature with heat pump	°C	61	61	61	61
Max. DHW temperature with heat pump only	°C	65	65	65	65
Maximum DHW temperature with emergency/booster heater	°C		63		63
Min./max. application limits, heat source for heat pump operation	°C	-5/+42	-5/+42	-5/+42	-5/+42
Min./max. application limits, cylinder ambient temperature	°C	-5/+55	-5/+55	-5/+55	-5/+55
Min. installation room floor area	m <sup>2</sup>	6	6	6	6
Min. installation room volume	m <sup>3</sup>	13	13	13	13
Maximum permissible operating pressure, cold water/DHW	MPa	0.8	0.8	0.8	0.8
Min./max. conductivity, drinking water	µS/cm	100-1500	100-1500	100-1500	100-1500
<b>Energy data</b>					
DHW heating energy efficiency class (load profile), indoor air		A (XL)	A (XL)	A (XL)	A (XL)
<b>Output details to EN 16147</b>					
Nominal DHW temperature (EN 16147)	°C	61	61	61	61
Nominal load profile (EN 16147)		XL	XL	XL	XL
Reference DHW temperature (EN 16147 / A15)	°C	59.4	59.4	59.4	59.4
Maximum available nominal amount of DHW at 40 °C (EN 16147 / A15)	l	334	334	469	469
Heat-up time (EN 16147 / A15)	h	8.01	8.01	11.19	11.19
Power consumption, standby period (EN 16147 / A15)	kW	0.051	0.051	0.070	0.070
COP (EN 16147 / A15)		3.00	3.00	3.04	3.04
<b>Output data</b>					
COP A15 / W10-61 (full heat-up)		3.52	3.52		
COP A15 / W10-55 (full heat-up)		3.75	3.75		
<b>Heating output</b>					
Average heating output (EN 16147 / A15)	kW	1.64	1.64	1.65	1.65
<b>Power consumption</b>					
Average heat pump power consumption (EN 16147 / A15)	kW	0.55	0.55	0.55	0.55
Max. heat pump power consumption (excl. start-up)	kW	0.65	0.65	0.65	0.65
Power consumption, emergency/booster heater	kW		1.5		1.5
Max. power consumption heat pump + emergency/booster heater	kW		2.2		2.2
<b>Electrical data</b>					
Rated voltage	V	230	230	230	230
Power supply		1/N/PE 220-240 V 50/60 Hz	1/N/PE 220-240 V 50/60 Hz	1/N/PE 220-240 V 50/60 Hz	1/N/PE 220-240 V 50/60 Hz
Permissible voltage range, external signal transducer		~ 220-240 V 50/60 Hz	~ 220-240 V 50/60 Hz	~ 220-240 V 50/60 Hz	~ 220-240 V 50/60 Hz
Max. operating current	A	3.18	9.70	3.18	9.70
Max. starting current	A	15.4	23.44	15.4	23.44
MCB/fuse rating	A	C10	C16	C10	C16
<b>Sound data</b>					
Sound power level (EN 12102)	dB(A)	60	60	60	60
Average sound pressure level at 1 m distance, free field	dB(A)	45	45	45	45
<b>Versions</b>					
IP rating		IP24	IP24	IP24	IP24
Refrigerant		R134a	R134a	R134a	R134a
Refrigerant charge	kg	0.85	0.85	0.85	0.85
Power cable length approx.	mm	2000	2000	2000	2000
<b>Dimensions</b>					
Height	mm	1545	1545	1913	1913
Diameter	mm	690	690	690	690
Height when tilted	mm	1692	1692	2034	2034
Height when tilted incl. packaging	mm	1895	1895	2230	2230
Packing unit dimensions height/width/depth	mm	1740/740/740	1740/740/740	2100/740/740	2100/740/740
<b>Weights</b>					
Weight, empty	kg	120	120	135	135
<b>Connections</b>					
Condensate connection		G 3/4 A	G 3/4 A	G 3/4 A	G 3/4 A
Safety valve connection		Rp 3/4	Rp 3/4	Rp 3/4	Rp 3/4
Water connection		G 1 A	G 1 A	G 1 A	G 1 A

# INSTALLATION

## Specification

Values		WWK 222	WWK 222 H	WWK 302	WWK 302 H
Type of anode		Impressed current anode	Impressed current anode	Impressed current anode	Impressed current anode
Air flow rate	m <sup>3</sup> /h	550	550	550	550

The output data refers to new appliances with clean heat exchangers.

Nominal data to EN 16147 – heat pump for recirculation air

### 15.3.1 Standardised output data

Explanations to determine and interpret the specified standardised output data

#### Standard: EN 16147

The output data specifically mentioned in text, diagrams and technical datasheets has been determined in line with the test conditions described in the standard shown in the heading of this chapter.

Generally, these standardised test conditions will not fully meet the conditions found at the installation site of the system user. Depending on the chosen test method and the extent to which the selected method deviates from the conditions described in the standard shown in the heading of this chapter, any deviations can have a considerable impact. Further factors that have an influence on the test values are the measuring equipment, the system configuration, the age of the system and the flow rates.

A confirmation of the specified output data can only be obtained if the conditions applicable to the relevant test match those of the standard shown in the heading of this chapter.

## Warranty Stiebel Eltron Australia Only - According to national regulations in Australia

Warranty for Heat Pumps – Models WWK 222, WWK 222 H, WWK 302 and WWK 302 H

### Who gives the warranty

1. The warranty is given by Stiebel Eltron (Aust) Pty Ltd (A.B.N. 82 066 271 083) of 6 Prohasky Street, Port Melbourne, Victoria, 3207 ("we", "us" or "our").

### The warranty

2. This warranty applies to Stiebel Eltron Heat Pumps – Models WWK 222, WWK 222 H, WWK 302 and WWK 302 H (the "unit") manufactured after 1 July 2015.
3. Subject to the warranty exclusions we will repair or replace, at our absolute discretion, a faulty component in your unit free of charge if it fails to operate in accordance with its specifications during the warranty period.
4. If we repair or replace a faulty component to your unit under this warranty, the warranty period is not extended from the time of the repair or replacement.
5. The warranty period commences on the date of completion of the installation of the unit. Where the date of completion of installation is not known, then the warranty period will commence 2 months after the date of manufacture.
6. The warranty period for a unit used for domestic purposes is shown in the table below. Domestic purposes means that the unit is used in a domestic dwelling.

Component	Warranty period
Cylinder and condenser	5 years from the date of completion of the installation of the unit.
Sealed refrigeration system, including compressor, evaporator, valves and associated pipe work	2 years from the date of completion of the installation of the unit.
All other componentry (electrical)	1 year from the date of completion of the installation of the unit.

7. The warranty period for a unit used for commercial purposes is shown in the table below. Commercial purposes means that the unit is used for a non-domestic purpose and includes but not limited to being used in a motel, hotel, mining camp or nursing home.

Component	Warranty period
Cylinder and condenser	2 years from the date of completion of the installation of the unit.
Sealed refrigeration system, including compressor, evaporator, valves and associated pipe work	2 years from the date of completion of the installation of the unit.
All other componentry (electrical)	2 years from the date of completion of the installation of the unit.

### Your entitlement to make a warranty claim

8. You are entitled to make a warranty claim if:
  - 8.1. you own the unit or if you have the owner's consent to represent the owner of the unit;
  - 8.2. you contact us within a reasonable time of discovering the problem with the unit;

### How you make a warranty claim

9. To make a warranty claim you must provide us with the following information:
  - 9.1. The model number of the unit;
  - 9.2. A description of the problem with the unit;
  - 9.3. The name, address and contact details (such as phone number and e-mail address) of the owner;
  - 9.4. The address where the unit is installed and the location (e.g. at side of house);
  - 9.5. The serial number of the unit;
  - 9.6. The date of purchase of the unit and the name of the seller of the unit;
  - 9.7. The date of installation of the unit;
  - 9.8. A copy of the certificate of compliance when the unit was installed.

10. The contact details for you to make your warranty claim are:

Name: Stiebel Eltron (Aust) Pty Ltd  
 Address: 6 Prohasky Street, Port Melbourne, Victoria, 3207  
 Telephone: 1800 153 351 (8.00 am to 5.00 pm AEST Monday to Friday)  
 Contact person: Customer Service Representative  
 E-mail: service@stiebel.com.au

11. We will arrange a suitable time with you to inspect and test the unit.

## Warranty exclusions

12. We may reject your warranty claim if:
- 12.1. The unit was not installed by a registered and qualified plumber.
  - 12.2. The unit was not installed and commissioned:
    - a) in Australia;
    - b) in accordance with the Operating and Installation Guide; and
    - c) in accordance with the relevant statutory and local requirements of the State or Territory in which the unit is installed.
  - 12.3. The unit has not been operated or maintained in accordance with the Operating and Installation Guide.
  - 12.4. The unit does not bear its original Serial Number or Rating Label.
  - 12.5. The unit was damaged by any or any combination of the following:
    - a) normal fair wear and tear;
    - b) connection to an incorrect water supply, for example where the water is highly conductive; where the water has a mineral content with a TDS > 2500 mg/L; or where the Langelier Saturation Index (LSI) of the water is outside the range  $-1.0 < \text{LSI} < 0.8$  (The LSI is a numeric value indicating whether water is scale forming or corrosive. It factors in pH, total alkalinity, calcium hardness and water temperature);
    - c) connection to water from a bore, dam or swimming pool;
    - d) connection to an incorrect power supply;
    - e) connection to faulty equipment, such as damaged valves;
    - f) insufficient air flow;
    - g) foreign matter in the water supply, such as sludge or sediment;
    - h) corrosive elements in the water supply;
    - i) inappropriate current impressed anode;
    - j) inappropriate current impressed anode battery maintenance;
    - k) accidental damage;
    - l) act of God, including damage by flood, storm, fire, lightning strike and the like;
    - m) excessive water pressure, negative water pressure (partial vacuum) or water pressure pulsation.
  - 12.6. The unit was damaged before it was installed e.g. it was damaged in transit.
  - 12.7. An unauthorised person has modified, serviced, repaired or attempted to repair the unit without our consent.
  - 12.8. Non genuine parts other than those manufactured or approved by us have been used on the unit.
  13. We may charge you:
    - 13.1. for any additional transport costs if the unit is installed more than 30 kilometres from our closest authorised service technician.
    - 13.2. for the extra time it takes our authorised service technician to access the unit for inspection and testing if it is not sited in accordance with the Operating and Installation Guide and not readily accessible for inspection.
    - 13.3. for any extra costs of our authorised service technician to make the unit safe for inspection.
  14. You must ensure that access to the unit by our authorised service technician is safe and free from obstruction.
  15. Our authorised service technician may refuse to inspect and test the unit until you provide safe and free access to it, at your cost.
  16. If we reject your warranty claim in accordance with clause 12, we may charge you for our authorised service technician's labour costs to inspect and test the unit.
  17. In order to properly test the unit we may remove it to another location for testing.

## Australian Consumer Law

18. Our goods come with guarantees that cannot be excluded under the Australian Consumer Law. You are entitled to a replacement or refund for a major failure and compensation for any other reasonably foreseeable loss or damage. You are also entitled to have the goods repaired or replaced if the goods fail to be of acceptable quality and the failure does not amount to a major failure.
19. The Stiebel Eltron warranty for the unit is in addition to any rights and remedies you may have under the Australian Consumer Law.

## ENVIRONMENT AND RECYCLING

Please help us to protect the environment by disposing of the packaging in accordance with the national regulations for waste processing.

### **Guarantee**

The guarantee conditions of our German companies do not apply to appliances acquired outside of Germany. In countries where our subsidiaries sell our products a guarantee can only be issued by those subsidiaries. Such guarantee is only granted if the subsidiary has issued its own terms of guarantee. No other guarantee will be granted.

We shall not provide any guarantee for appliances acquired in countries where we have no subsidiary to sell our products. This will not affect warranties issued by any importers.

### **Environment and recycling**

We would ask you to help protect the environment. After use, dispose of the various materials in accordance with national regulations.

#### **KYOTO | R134a**

This device is filled with refrigerant R134a.

Refrigerant R134a is a CFC greenhouse gas mentioned in the Kyoto protocol with a global greenhouse potential (GWP) = 1300.

Never release refrigerant R134a to atmosphere.

---

## NOTES

---

## Deutschland

STIEBEL ELTRON GmbH & Co. KG  
Dr.-Stiebel-Straße 33 | 37603 Holzminden  
Tel. 05531 702-0 | Fax 05531 702-480  
info@stiebel-eltron.de  
www.stiebel-eltron.de

## Verkauf

Tel. 05531 702-110 | Fax 05531 702-95108 | info-center@stiebel-eltron.de

## Kundendienst

Tel. 05531 702-111 | Fax 05531 702-95890 | kundendienst@stiebel-eltron.de

## Ersatzteilverkauf

Tel. 05531 702-120 | Fax 05531 702-95335 | ersatzteile@stiebel-eltron.de

## Australia

STIEBEL ELTRON Australia Pty. Ltd.  
6 Prohasky Street | Port Melbourne VIC 3207  
Tel. 03 9645-1833 | Fax 03 9645-4366  
info@stiebel.com.au  
www.stiebel.com.au

## Austria

STIEBEL ELTRON Ges.m.b.H.  
Eferdinger Str. 73 | 4600 Wels  
Tel. 07242 47367-0 | Fax 07242 47367-42  
info@stiebel-eltron.at  
www.stiebel-eltron.at

## Belgium

STIEBEL ELTRON bvba/sprl  
't Hofveld 6 - D1 | 1702 Groot-Bijgaarden  
Tel. 02 42322-22 | Fax 02 42322-12  
info@stiebel-eltron.be  
www.stiebel-eltron.be

## China

STIEBEL ELTRON (Guangzhou) Electric  
Appliance Co., Ltd.  
Rm 102, F1, Yingbin-Yihao Mansion, No. 1  
Yingbin Road  
Panyu District | 511431 Guangzhou  
Tel. 020 39162209 | Fax 020 39162203  
info@stiebeleltron.cn  
www.stiebeleltron.cn

## Czech Republic

STIEBEL ELTRON spol. s r.o.  
K Hájiřm 946 | 155 00 Praha 5 - Stodůlky  
Tel. 251116-111 | Fax 235512-122  
info@stiebel-eltron.cz  
www.stiebel-eltron.cz

## Finland

STIEBEL ELTRON OY  
Kapinakuja 1 | 04600 Mäntsälä  
Tel. 020 720-9988  
info@stiebel-eltron.fi  
www.stiebel-eltron.fi

## France

STIEBEL ELTRON SAS  
7-9, rue des Selliers  
B.P 85107 | 57073 Metz-Cédex 3  
Tel. 0387 7438-88 | Fax 0387 7468-26  
info@stiebel-eltron.fr  
www.stiebel-eltron.fr

## Hungary

STIEBEL ELTRON Kft.  
Gyár u. 2 | 2040 Budaörs  
Tel. 01 250-6055 | Fax 01 368-8097  
info@stiebel-eltron.hu  
www.stiebel-eltron.hu

## Japan

NIHON STIEBEL Co. Ltd.  
Kowa Kawasaki Nishiguchi Building 8F  
66-2 Horikawa-Cho  
Saiwai-Ku | 212-0013 Kawasaki  
Tel. 044 540-3200 | Fax 044 540-3210  
info@nihonstiebel.co.jp  
www.nihonstiebel.co.jp

## Netherlands

STIEBEL ELTRON Nederland B.V.  
Daviottenweg 36 | 5222 BH 's-Hertogenbosch  
Tel. 073 623-0000 | Fax 073 623-1141  
info@stiebel-eltron.nl  
www.stiebel-eltron.nl

## Poland

STIEBEL ELTRON Polska Sp. z O.O.  
ul. Działkowa 2 | 02-234 Warszawa  
Tel. 022 60920-30 | Fax 022 60920-29  
biuro@stiebel-eltron.pl  
www.stiebel-eltron.pl

## Russia

STIEBEL ELTRON LLC RUSSIA  
Urzhumskaya street 4,  
building 2 | 129343 Moscow  
Tel. 0495 7753889 | Fax 0495 7753887  
info@stiebel-eltron.ru  
www.stiebel-eltron.ru

## Slovakia

TATRAMAT - ohrievače vody s.r.o.  
Hlavná 1 | 058 01 Poprad  
Tel. 052 7127-125 | Fax 052 7127-148  
info@stiebel-eltron.sk  
www.stiebel-eltron.sk

## Switzerland

STIEBEL ELTRON AG  
Industrie West  
Gass 8 | 5242 Lupfig  
Tel. 056 4640-500 | Fax 056 4640-501  
info@stiebel-eltron.ch  
www.stiebel-eltron.ch

## Thailand

STIEBEL ELTRON Asia Ltd.  
469 Moo 2 Tambol Klong-Jik  
Amphur Bangpa-In | 13160 Ayutthaya  
Tel. 035 220088 | Fax 035 221188  
info@stiebeleltronasia.com  
www.stiebeleltronasia.com

## United Kingdom and Ireland

STIEBEL ELTRON UK Ltd.  
Unit 12 Stadium Court  
Stadium Road | CH62 3RP Bromborough  
Tel. 0151 346-2300 | Fax 0151 334-2913  
info@stiebel-eltron.co.uk  
www.stiebel-eltron.co.uk

## United States of America

STIEBEL ELTRON, Inc.  
17 West Street | 01088 West Hatfield MA  
Tel. 0413 247-3380 | Fax 0413 247-3369  
info@stiebel-eltron-usa.com  
www.stiebel-eltron-usa.com



Irrtum und technische Änderungen vorbehalten! | Subject to errors and technical changes! | Sous réserve d'erreurs et de modifications techniques! | Onder voorbehoud van vergissingen en technische wijzigingen! | Salvo error o modificación técnica! | Excepto erro ou alteração técnica | Zastrzeżone zmiany techniczne i ewentualne błędy | Omyly a technické změny jsou vyhrazeny! | A muszaki változtatások és tévedések jogát fenntartjuk! | Отсутствие ошибок не гарантируется. Возможны технические изменения. | Chyby a technické zmeny sú vyhradené! Stand 9046

**STIEBEL ELTRON**