



# AMBIHEAT HDc-270 HEAVY DUTY HEAT PUMP

## PLATINUM SERIES



COP OF  
4.5kW



PEOPLE

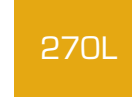

CAPACITY



CYLINDER  
(supply only)  
WARRANTY

## AMBIHEAT HDc-270 HEAVY DUTY HEAT PUMP

AMBIHEAT HDc-270 Heat Pump is a smart, energy efficient alternative for areas where a traditional solar water heater may not be suitable. It uses the heat from the surrounding air, to heat your water and provides a reliable, efficient and sustainable way to reduce your water heating energy consumption. A Heat Pump works day and night as it extracts heat from the surrounding air and doesn't rely on direct sunlight to operate.



## FEATURES

- Advanced wrap around microchannel heating technology for uniform and faster water heating
- Suitable for cold climates with an operating range from -5°C to +43°C<sup>5</sup>
- Suitable for harsh water conditions<sup>2</sup>
- Save up to 68% on your water heating energy consumption compared to an electric water heater in Zone 3<sup>3</sup>
- High recovery rate
- 2.4kW back-up element
- User-friendly touch screen LED display
- Eligible for Government Incentives
- 7 year cylinder warranty<sup>4</sup>
- Suitable for 2 to 5 people

## WHY CHOOSE RHEEM HEAT PUMP?

AMBIHEAT Heat Pump has been designed and tested to withstand the harsh Australian conditions:

- Enamel lined water tank:** The enamel coating reduces the risk of corrosion and water leakage.
- Microchannel technology:** Provide a larger contact area for more efficient water heating.
- Side fan design:** Design specially developed to protect the unit from rain.
- Durable top cover:** With its durable ASA top cover\*, the unit can easily withstand all weather conditions.
- Smart LED controller display:** A bright interactive LED touchscreen display putting control at your fingertips.



\* Acrylonitrile Butadiene Styrene (ABS) is an opaque thermoplastic and amorphous polymer and Acrylonitrile Styrene Acrylate (ASA), also called Acrylic Styrene Acrylonitrile, is an amorphous thermoplastic with improved weather resistance.





# AMBIHEAT HDc-270 HEAVY DUTY HEAT PUMP

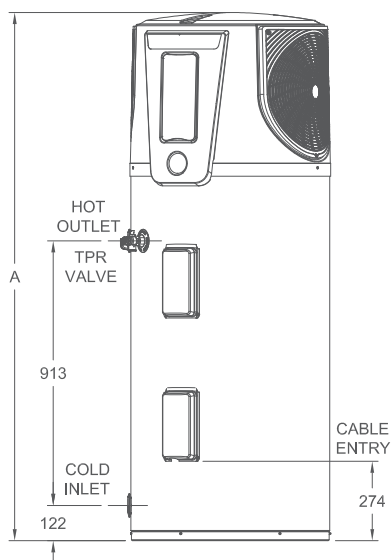
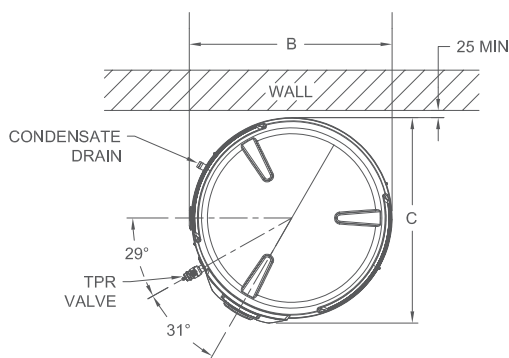

## PRODUCT INFORMATION

MODEL	UNIT	HDc-270
<b>System</b>		<b>551270</b>
Storage capacity	litres	270
Boost capacity	litres	195
Rated heat pump power input	watts	985
Element rating	kW	2.4
Coefficient of Performance (COP)*		4.5
People per household		2 to 5
<b>Dimensions &amp; specifications</b>		
Tank height (A)	mm	1825
Tank width (B)	mm	730
Tank depth (C)	mm	760
System weight - empty	kg	136
System weight - full	kg	306
Refrigerant		R134a
<b>Water connections &amp; settings</b>		
Inlet		RP 3/4
Outlet		RP 3/4
Temp Press Relief (TPR) Valve setting	kPa	1000
Expansion Control Valve (ECV) setting	kPa	850
<b>Maximum mains supply pressure</b>		
With expansion control valve	kPa	680
Without expansion control valve	kPa	800

\*Testing at ambient temperature: 200/15°C (Dry Bulb/Wet Bulb) and ambient temperature from 15°C to 55°C for water heater operation.

- ZONE 1
- ZONE 2
- ZONE 3
- ZONE 4
- ZONE 5

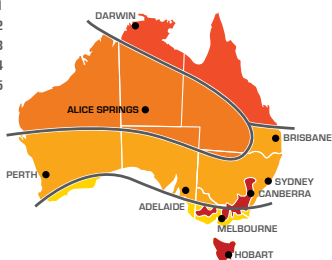

## STCs

Small-scale Technology Certificates (STCs) are a financial benefit to encourage the installation of solar water heaters provided under a Federal Government legislated scheme.

This map shows the climate Zones within Australia which will define the number of STCs allocated to an approved solar water heater. Your installation may be eligible<sup>3</sup>.

For more information on STCs visit [www.rheem.com.au/rheem/help/offers-and-incentives/stcs](http://www.rheem.com.au/rheem/help/offers-and-incentives/stcs)

<sup>1</sup> Testing at ambient temperature: 19°C/15°C (Dry Bulb/Wet Bulb) and ambient temperature from 15°C to 55°C for water heater operation.

<sup>2</sup> Warranty limits regarding water chemistry. Harsh water regions – the Rheem warranty may not apply if the water heater is connected to a water supply which: has a Chloride content >250mg/L; a pH <6.0 or >9.5; has a Total Dissolved Solids content >600mg/L; is scaling with a Saturation Index >+0.8, or; is corrosive with a Saturation Index <-1.0.

<sup>3</sup> Energy savings of up to 64% to 71% are based on Australian Government approved TRNSYS simulation modelling using a medium load and apply when replacing an electric water heater with a Rheem 551270 Heat Pump water heater. Energy savings of up to and between 64% to 71% in Zone 1 to 5 on hot water energy consumption when replacing an electric water heater (min 16 hours/day). Any savings will vary depending upon your location, type of water heater being replaced, hot water consumption and fuel tariff. Zone 1 - 71.2%, Zone 2 - 93.9%, Zone 3 - 68.5%, Zone 4 - 65.5% and Zone 5 - 64.1%

<sup>4</sup> Warranty Periods: 7 years supply on cylinder, 3 years labour on cylinder, 3 years on sealed system including labour, 1 year supply and labour on all other parts. Applies to single family domestic dwelling only. Conditions apply. See the Rheem warranty set out in the Owner's Guide and Installation Instructions or view at [www.rheem.com.au/warranty](http://www.rheem.com.au/warranty).

<sup>5</sup> The specified -5°C to 43°C temperature range limits the unit's heat pump operations, the electric boost element takes over the heat pump operation when the ambient temperature falls outside of this temperature range. Materials and specifications are subject to change without notice.

© Registered Trademark of Rheem Australia Pty Ltd.

™ Trademark of SAI Global.



Australian Standard  
AS/NZS 2712  
Lic SMKP20142  
SAI Global



Quality ISO 9001



AS 3498 WMKA00200  
SAI Global



A Greater Degree of Good™ represents our global commitment to sustainability.

Rheem Australia Pty Ltd.

1 Alan Street, Rydalmere, NSW 2116 Australia  
PO Box 7508, Silverwater NSW 2128 Australia  
[www.rheem.com.au](http://www.rheem.com.au)

