



# INSTRUCTION MANUAL

Integrated Heat Pump Water Heater  
Model no:

- OMNIXHP-180-R290
- OMNIXHP-250-R290
- OMNIXHP-340-R290
- OMNIXHP-420-R290



# Thank you for choosing



Omni X is a next-generation heat pump water heater designed for efficiency, reliability, and sustainability. Every Omni X unit is engineered to deliver years of consistent hot water performance while helping you reduce energy costs and environmental impact.

To ensure the best results, it is essential that your Omni X system is installed and operated according to the instructions in this manual. With correct installation and minimal maintenance, your Omni X will provide dependable, high-quality hot water for your home or business, giving you peace of mind and long-term value.

Enjoy the comfort, savings, and innovation of your new Omni X hot water system.

# TABLE OF CONTENTS

## 1. General Information

1.1 Important information .....	4
1.2 For R290 Refrigerant appliance .....	5

## 2. Installation & Application

2.1 Installation Location Selection .....	6
2.2 Installation Illustration .....	7
2.3 Service Operations (Important) .....	9

## 3. Control System

3.1 The Key Pad .....	14
3.2 Buttons Function .....	14
3.3 Lock/Unlock the Buttons .....	14
3.4 On/Off the Unit .....	15
3.5 Set Water Temperature .....	15
3.6 Set the Clock .....	15
3.7 Set/Cancel the Timer (On/Off) .....	15
3.8 Working Status Query .....	16
3.9 Review/Set the Parameters (For Technician Only) .....	16
3.10 Protection .....	17

## 4. Troubleshooting .....

19

## 5. Wiring Diagram

5.1 Fuse Information .....	22
----------------------------	----

## Appendices

Appendix 1: How to Connect the Heat Pump Controller to Your Cell Phone .....	23
Appendix 2: How to Set the Timer by Your Cell Phone .....	26

The water heater shall be installed, maintained, and repaired by qualified individuals who are specially trained and experienced in the installation and maintenance of this type of equipment.

Persons who are not qualified shall not attempt to install, service, or maintain this equipment.

- ◆ Please read this manual carefully before installation.
- ◆ Please keep this manual in a safe place for future reference.

# 1. GENERAL INFORMATION

## Important Information

The water heater shall be installed in accordance with the following requirements:

- For Australia: AS/NZS 3500.4 and the requirements of the appropriate regulatory authority.
- For New Zealand: Clause G12 of the NZ Building Code.

The heat pump must be installed by a licensed plumber in compliance with the guidelines specified in AS/NZS 3500.2, which pertains to the National Plumbing and Drainage Code for Hot Water Supply Systems – Acceptable Solutions.

The installation shall conform to the Plumbing Code of Australia (PCA). All pipe installations must comply with the relevant provisions of Australian Standard AS 3500.4 or NZBC G12. Only pipe materials considered acceptable under AS/NZS 3500.4 or NZBC G12 shall be used.

**THIS APPLIANCE MAY DELIVER WATER AT HIGH TEMPERATURE. REFER TO THE PLUMBING CODE OF AUSTRALIA (PCA), LOCAL REQUIREMENTS, AND INSTALLATION INSTRUCTIONS TO DETERMINE IF ADDITIONAL DELIVERY TEMPERATURE CONTROL IS REQUIRED.**

**THIS APPLIANCE MUST ONLY BE INSTALLED IN ACCORDANCE WITH THE ACCEPTABLE PLUMBING CONFIGURATIONS SPECIFIED IN THESE INSTRUCTIONS. FAILURE TO DO SO MAY RESULT IN INADEQUATE DELIVERY TEMPERATURE CONTROL.**



For your safety, and to ensure proper operation of the unit, this heat pump must be installed and repaired by a qualified technician.



A leakage protection switch must be installed near the heat pump in an accessible location.



Do not use damaged wires or switches. If damage is found, replace them immediately.



Do not open the electrical box without first shutting off all power sources to the heat pump.



When transporting the heat pump, keep it upright and do not tilt it more than 45° in any direction.



Before performing any maintenance, turn off the unit and disconnect it from the power supply.



Do not install the unit in areas where there are flammable or explosive materials.



Do not restrict or block the air intake or outlet of the unit.



When the unit is not used for an extended period, switch it off and disconnect the power supply. Drain the unit when the ambient temperature is below 0°C.



If a power failure lasts more than 5 hours and the ambient temperature is below 2°C, drain the unit to prevent the formation of ice.



This appliance is not intended for use by persons (including children) with reduced physical, sensory or mental capabilities, or by those lacking experience or knowledge, unless supervised or instructed by a person responsible for their safety.



Maintain a safe distance between the unit and other equipment or structures. Ensure adequate space for access during maintenance and service operations.



Children should be supervised to ensure they do not play with the appliance.



If the supply cord is damaged, it must be replaced by the manufacturer, its service agent, or a similarly qualified person in order to avoid a hazard.



An all-pole disconnection device with at least 3 mm clearance on all poles must be incorporated in the fixed wiring, in accordance with the wiring rules. The device should be rated for leakage current that may exceed 10 mA, and the residual current device (RCD) must have a rated residual operating current not exceeding 30 mA.



The appliance shall be installed in accordance with national wiring regulations.



Power supply: the cross-section of the electrical cables must be adequate for the unit's power rating, and the supply voltage must match the value indicated on the unit. All units must be earthed in accordance with legislation in force in the country concerned.



Do not use methods to accelerate the defrosting process or to clean the unit, other than those recommended by the manufacturer.



The appliance must be stored in a well-ventilated area where the room size is suitable for operation.



All safety-related procedures shall only be carried out by competent persons.



The appliance must be stored in a room without continuously operating ignition sources (for example, open flames, gas appliances, or electric heaters).



Do not pierce or burn the unit.



Be aware that refrigerants may not contain an odour.

## For R290 Refrigerant Appliance

- The refrigerant (R290) is contained within the refrigerant circuit of the appliance. It is a natural gas with high environmental compatibility, but it is flammable.
- During transportation and installation of the appliance, ensure that none of the components of the refrigerant circuit are damaged.
- The refrigerant (R290) is flammable.
- If the refrigerant circuit is damaged:
  - Avoid open flames and sources of ignition.
  - Thoroughly ventilate the room where the appliance is located.
- The appliance is supplied with flammable refrigerant (R290). It must be transported and installed with the utmost care, as excessive knocking or shaking could damage the refrigerant circuit.
- Keep ventilation openings in the appliance enclosure or in the built-in structure free from obstruction.
- Do not use mechanical devices or other means to accelerate the defrosting process, other than those recommended by the manufacturer.
- Do not damage the refrigerant circuit.
- Do not use electrical appliances inside the food storage compartments of the appliance, unless they are of the type recommended by the manufacturer.



“No Smoking” signs must be displayed.

# 2. INSTALLATION & APPLICATION

## Transportation

When transporting the heat pump, keep it upright and do not tilt it more than 45° in any direction.

## Installation Location Selection

It is very important to select a proper position for the unit. Please consider the following:

- The heat pump must have good ventilation.
- The installation location should be close to a drainage channel to allow condensate water to discharge easily.
- Choose a smooth, horizontal surface that can support the weight of the unit and minimise noise and vibration.
- Do not install the unit in areas where there is pollution, accumulated dirt, or fallen leaves.
- Do not install the unit near flammable or explosive materials.

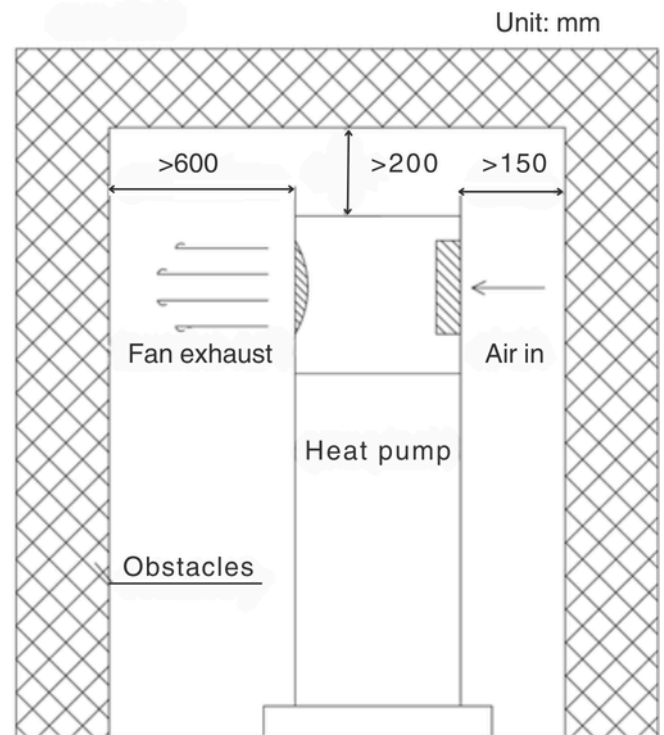
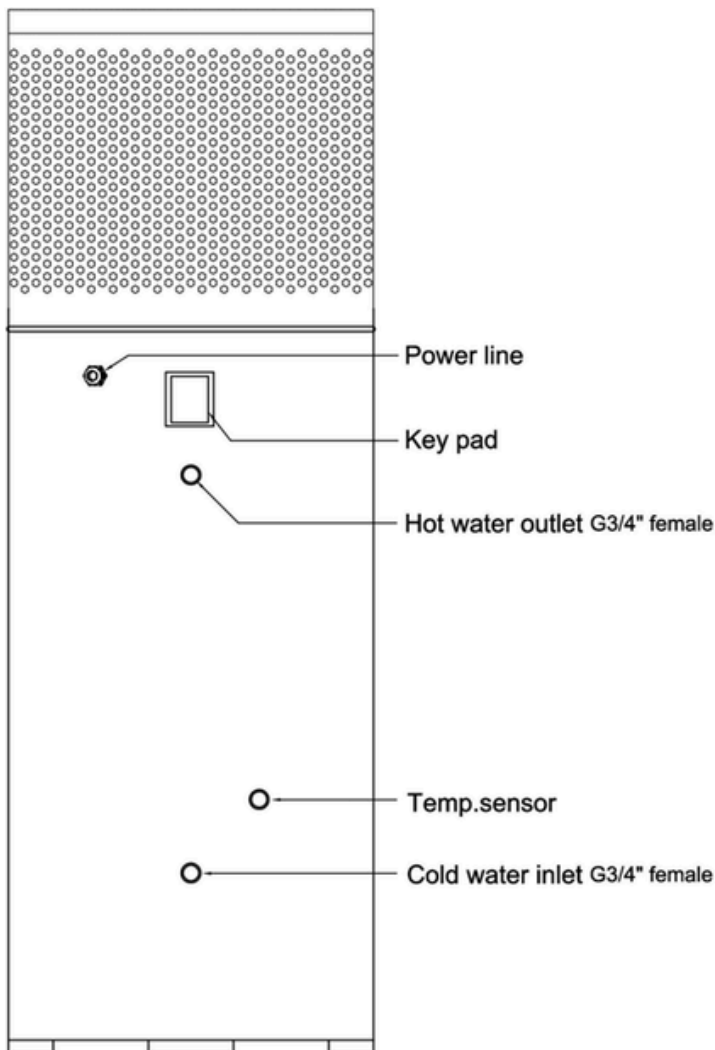

Distance requirement for heat pump

Remark: The heat pump must be fixed to avoid topple.

Note:  
Condensate water connector  
and Relief valve connector on  
the other side of tank.

## Installation illustration

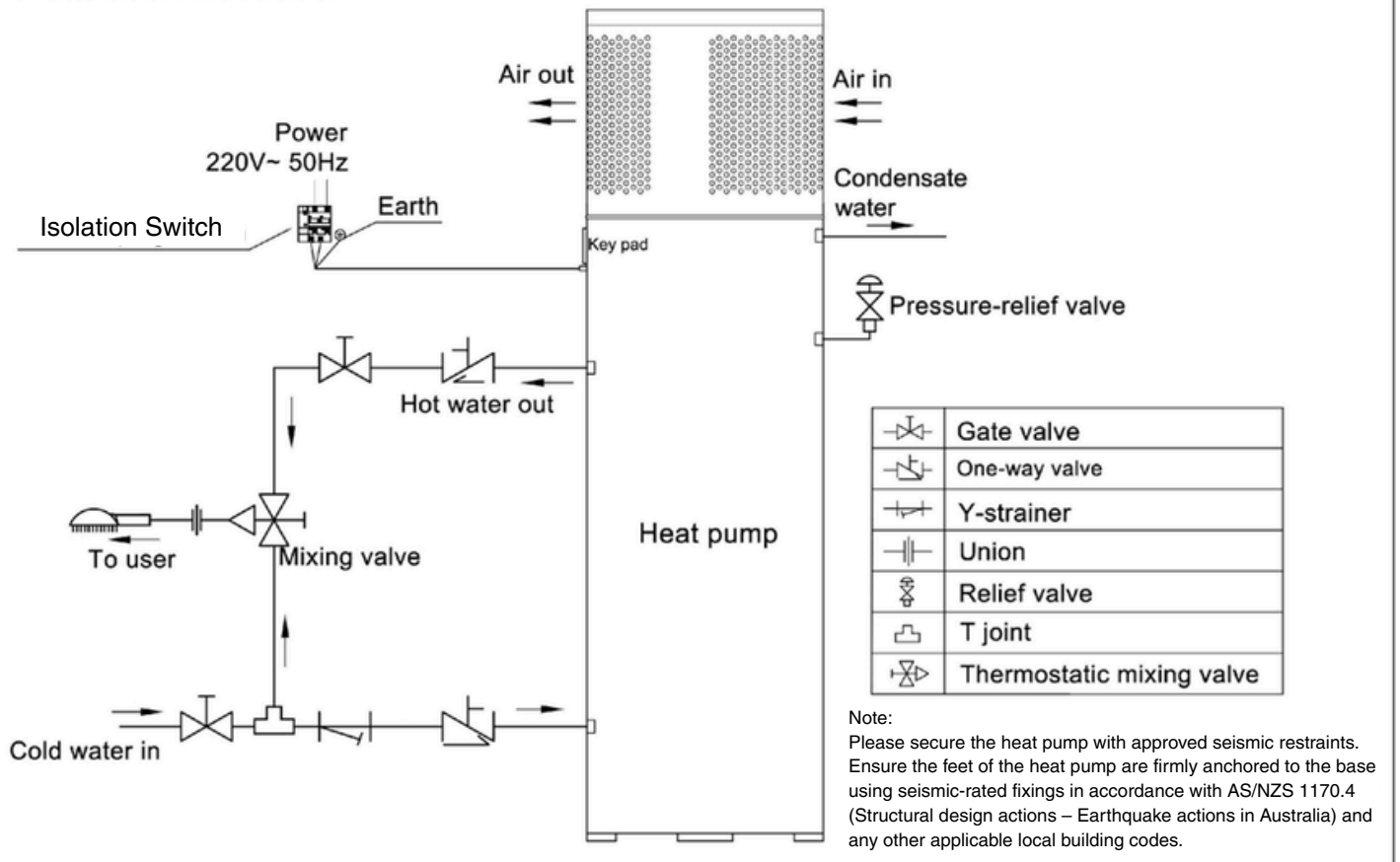

### Note: Water Quality

- If the water quality is poor and contains higher levels of scale or sand, it should be filtered using a filter of approximately 40 mesh.
- The total hardness requirement is no more than 50 ppm.
- Always install a wye strainer before the water inlet of the unit to prevent clogging of the system.
- **PTR Valve & Pressure Reducing Valve**
- This water heater is equipped with a PTR (Pressure and Temperature Relief) valve rated at:
  - Pressure: 700 kPa
  - Temperature: 99°C
  - Power: 10.0 kW
- This water heater is equipped with a ECV (Expansion control valve) valve rated at:
  - Pressure: 600 kPa
  - Power: 10.0 kW
- It is an essential requirement to install a PTR valve & ECV on the water tank. The valves are intended for direct connection to the mains water supply, provided that the water pressure does not exceed this rating.
- If the mains water pressure fluctuates above 500 kPa, it is advisable to install a pressure limiting device (AS1357) at the specified connection point for added safety and protection.

### Non-Return / Isolation Valve

It is necessary to install a non-return or isolation valve directly in the cold-water supply line that feeds the system. This valve enables the isolation of the hot water system from the rest of the home's water supply, simplifying maintenance, draining, and unit replacement. Do not use a hose set to connect the system to the water supply. The non-return or isolation valve can be used in combination with a PTR valve to create a dual-valve system.

## Tempering Valve

- The heat pumps are configured to generate hot water at temperatures exceeding 50°C. To comply with AS/NZS 3500 regulations, it is imperative to have a tempering valve installed. As shown in the figure, the length of Pipe 1 must be at least 150 mm.
- The circulation pipes and valves must be well insulated; otherwise, heat will be lost or freezing may occur.
- Wire the power of the heat pump water heater (refer to the wiring diagram). Make sure the voltage is stable when giving a trial run to the unit.
- Water may drip from the discharge pipe of the pressure-relief device, and this pipe must be left open to the atmosphere.
- The pressure-relief device is to be operated regularly to remove lime deposits and to verify that it is not blocked.
- A discharge pipe connected to the pressure-relief device must be installed in a downward direction and in a frost-free environment.

## Electrical Connection



For your own security, and to ensure proper operation of the unit, this heat pump must be installed and repaired by a qualified technician, not the consumer.



Do not use any damaged wires or switches. If found to be damaged, replace them immediately.



An all-pole disconnection device with 3 mm clearance on all poles must be installed in accordance with AS/NZS 3000, together with an RCD not exceeding 30 mA.



Do not open the electrical box without shutting off all power sources to the heat pump.

- All wiring must meet electrical safety requirements and be conducted by qualified electricians.
- Ensure that there is a good earth connection for the power. Do not disconnect the earth connection of the power under any circumstances.
- Ensure that the heat pump water heater is well connected to earth.
- When the water heater is connected to the electricity network, there must be short-circuit protection.
- Do not use the main power switch to control the start/stop of the unit.
- After installation, double-check before connecting it to the power.

## Trial Operation

- To ensure that start-up is performed correctly, it should only be operated by a qualified technician.
  - The heat pump water heater is designed according to the following conditions:
    - The range of ambient temperature is -7°C to 43°C.
    - Permitted minimum–maximum filling water pressure: 200–650 kPa.
    - The range of water inlet temperature is 0–35°C.
    - The range of water outlet temperature is 60°C.
- **Important:** Make sure the piping system and water tank are completely filled with water before commissioning.

The following items need to be checked prior to start-up:

1. The heat pump must be fully connected.
2. All valves that could impair the proper flow of water in the heating circuit must be open.
3. The air intake and air outlet paths must be clear.
4. Ensure the condensate outflow functions.
5. Open the gate valve to fill the piping system and water tank.

# Service Operations

## WARNING

- Do not use methods to accelerate the defrosting process or to clean the unit, other than those recommended by the manufacturer.
- The appliance shall be stored in a room without continuously operating ignition sources (for example: open flames, gas appliances, or electric heaters).
- Do not pierce or burn the unit.
- Be aware that refrigerants may not contain an odour.
  
- Any person who is involved with working on or breaking into a refrigerant circuit should hold a current, valid certificate from an industry-accredited assessment authority, which authorises their competence to handle refrigerants safely in accordance with an industry-recognised assessment specification.
- Servicing shall only be performed as recommended by the equipment manufacturer.
- Maintenance and repair requiring the assistance of other skilled personnel shall be carried out under the supervision of a person competent in the use of flammable refrigerants.

Service personnel shall be instructed to undertake the following when servicing an appliance that employs a flammable refrigerant.

- Prior to beginning work on systems containing flammable refrigerants, safety checks are necessary to ensure that the risk of ignition is minimised. For repair to the refrigerating system, the following precautions shall be complied with prior to conducting work on the system.
- Work shall be undertaken under a controlled procedure so as to minimise the risk of a flammable gas or vapour being present while the work is being performed.
- All maintenance staff and others working in the local area shall be instructed on the nature of work being carried out. Work in confined spaces shall be avoided. The area around the workspace shall be sectioned off. Ensure that the conditions within the area have been made safe by control of flammable material.
- The area shall be checked with an appropriate refrigerant detector prior to and during work, to ensure the technician is aware of potentially flammable atmospheres. Ensure that the leak detection equipment being used is suitable for use with flammable refrigerants, i.e. non-sparking, adequately sealed, or intrinsically safe.
- If any hot work is to be conducted on the refrigeration equipment or any associated parts, appropriate fire extinguishing equipment shall be available to hand. Have a dry powder or CO<sub>2</sub> fire extinguisher adjacent to the charging area.
- No person carrying out work in relation to a refrigeration system which involves exposing any pipework that contains or has contained flammable refrigerant shall use any sources of ignition in such a manner that it may lead to the risk of fire or explosion. All possible ignition sources, including cigarette smoking, should be kept sufficiently far away from the site of installation, repairing, removing, and disposal, during which flammable refrigerant can possibly be released to the surrounding space. Prior to work taking place, the area around the equipment is to be surveyed to make sure that there are no flammable hazards or ignition risks. "No Smoking" signs shall be displayed.
- Ensure that the area is in the open or that it is adequately ventilated before breaking into the system or conducting any hot work. A degree of ventilation shall continue during the period that the work is carried out. The ventilation should safely disperse any released refrigerant and preferably expel it externally into the atmosphere.
- Where electrical components are being changed, they shall be fit for the purpose and to the correct specification. At all times the manufacturer's maintenance and service guidelines shall be followed. If in doubt, consult the manufacturer's technical department for assistance.

The following checks shall be applied to installations using flammable refrigerants:

- The charge size is in accordance with the room size within which the refrigerant-containing parts are installed;
- The ventilation machinery and outlets are operating adequately and are not obstructed;
- If an indirect refrigerating circuit is being used, the secondary circuit shall be checked for the presence of refrigerant;
- Marking to the equipment continues to be visible and legible. Markings and signs that are illegible shall be corrected;
- Refrigeration pipe or components are installed in a position where they are unlikely to be exposed to any substance which may corrode refrigerant-containing components, unless the components are constructed of materials which are inherently resistant to being corroded or are suitably protected against being so corroded.
- Repair and maintenance to electrical components shall include initial safety checks and component inspection procedures. If a fault exists that could compromise safety, then no electrical supply shall be connected to the circuit until it is satisfactorily dealt with. If the fault cannot be corrected immediately but it is necessary to continue operation, an adequate temporary solution shall be used. This shall be reported to the owner of the equipment so all parties are advised. Capacitors shall be discharged in a safe manner to avoid the possibility of sparking; continuity of earth bonding shall be confirmed.
- During repairs to sealed components, all electrical supplies shall be disconnected from the equipment being worked upon prior to any removal of sealed covers, etc. If it is absolutely necessary to have an electrical supply to equipment during servicing, then a permanently operating form of leak detection shall be located at the most critical point to warn of a potentially hazardous situation. Particular attention shall be paid to the following to ensure that by working on electrical components, the casing is not altered in such a way that the level of protection is affected. This shall include damage to cables, excessive number of connections, terminals not made to original specification, damage to seals, incorrect fitting of glands, etc.
- Ensure that apparatus is mounted securely.
- Ensure that seals or sealing materials have not degraded such that they no longer serve the purpose of preventing the ingress of flammable atmospheres.
- Intrinsically safe components do not have to be isolated prior to working on them.
- Check that cabling will not be subject to wear, corrosion, excessive pressure, vibration, sharp edges, or any other adverse environmental effects. The check shall also take into account the effects of ageing or continual vibration from sources such as compressors or fans.
- Under no circumstances shall potential sources of ignition be used in the searching for or detection of refrigerant leaks. A halide torch (or any other detector using a naked flame) shall not be used. Ensure that no live electrical components and wiring are exposed while charging, recovering, or purging the system; all procedures shall be carried out in accordance with the manufacturer's specifications.

The following leak detection methods are deemed acceptable for systems containing flammable refrigerants.

- Electronic leak detectors shall be used to detect flammable refrigerants, but the sensitivity may not be adequate, or may need re-calibration. (Detection equipment shall be calibrated in a refrigerant-free area.) Ensure that the detector is not a potential source of ignition and is suitable for the refrigerant used. Leak detection equipment shall be set at a percentage of the LFL of the refrigerant and shall be calibrated to the refrigerant employed, and the appropriate percentage of gas (25% maximum) shall be confirmed.
- Leak detection fluids are suitable for use with most refrigerants, but the use of detergents containing chlorine shall be avoided as the chlorine may react with the refrigerant and corrode the copper pipework.
- If a leak is suspected, all naked flames shall be removed or extinguished.
- If a leakage of refrigerant is found which requires brazing, all of the refrigerant shall be recovered from the system, or isolated (by means of shut-off valves) in a part of the system remote from the leak. Oxygen-free nitrogen (OFN) shall then be purged through the system both before and during the brazing process.
- When breaking into the refrigerant circuit to make repairs – or for any other purpose – conventional procedures shall be used. However, it is important that best practice is followed since flammability is a consideration. The following procedure shall be adhered to:
  - Remove refrigerant;
  - Purge the circuit with inert gas;
  - Evacuate;
  - Purge again with inert gas;
  - Open the circuit by cutting or brazing.
- The refrigerant charge shall be recovered into the correct recovery cylinders. The system shall be flushed with OFN to render the unit safe. This process may need to be repeated several times. Compressed air or oxygen shall not be used for this task.
- Flushing shall be achieved by breaking the vacuum in the system with OFN and continuing to fill until the working pressure is achieved, then venting to atmosphere, and finally pulling down to a vacuum. This process shall be repeated until no refrigerant remains within the system. When the final OFN charge is used, the system shall be vented down to atmospheric pressure to enable work to take place. This operation is absolutely vital if brazing operations on the pipework are to take place. Ensure that the outlet for the vacuum pump is not close to any ignition sources and that ventilation is available.

In addition to conventional charging procedures, the following requirements shall be followed:

- Ensure that contamination of different refrigerants does not occur when using charging equipment. Hoses or lines shall be as short as possible to minimise the amount of refrigerant contained in them.
- Cylinders shall be kept upright.
- Ensure that the refrigeration system is earthed prior to charging the system with refrigerant.
- Label the system when charging is complete (if not already).
- Extreme care shall be taken not to overfill the refrigeration system.
- Prior to recharging the system, it shall be pressure-tested with OFN. The system shall be leak tested on completion of charging but prior to commissioning. A follow-up leak test shall be carried out prior to leaving the site.
- Before carrying out this procedure, it is essential that the technician is completely familiar with the equipment and all its details. It is recommended as good practice that all refrigerants are recovered safely. Prior to the task being carried out, an oil and refrigerant sample shall be taken in case analysis is required prior to re-use of reclaimed refrigerant. It is essential that electrical power is available before the task is commenced.

- Become familiar with the equipment and its operation.
  - Isolate the system electrically.
  - Before attempting the procedure ensure that:
    - Mechanical handling equipment is available, if required, for handling refrigerant cylinders;
    - All personal protective equipment is available and being used correctly;
    - The recovery process is supervised at all times by a competent person;
    - Recovery equipment and cylinders conform to the appropriate standards.
  - Pump down the refrigerant system, if possible.
  - If a vacuum is not possible, make a manifold so that refrigerant can be removed from various parts of the system.
  - Make sure that the cylinder is situated on the scales before recovery takes place.
  - Start the recovery machine and operate in accordance with the manufacturer's instructions.
  - Do not overfill cylinders (no more than 80% volume liquid charge).
  - Do not exceed the maximum working pressure of the cylinder, even temporarily.
  - When the cylinders have been filled correctly and the process completed, make sure that the cylinders and the equipment are removed from site promptly and all isolation valves on the equipment are closed off.
  - Recovered refrigerant shall not be charged into another refrigeration system unless it has been cleaned and checked.
- Equipment shall be labelled stating that it has been decommissioned and emptied of refrigerant. The label shall be dated and signed. Ensure that there are labels on the equipment stating that the equipment contains flammable refrigerant.
  - When removing refrigerant from a system, either for servicing or decommissioning, it is recommended as good practice that all refrigerants are removed safely.
  - When transferring refrigerant into cylinders, ensure that only appropriate refrigerant recovery cylinders are employed. Ensure that the correct number of cylinders for holding the total system charge are available. All cylinders to be used shall be designated for the recovered refrigerant and labelled for that refrigerant (i.e. special cylinders for the recovery of refrigerant). Cylinders shall be complete with a pressure relief valve and associated shut-off valves in good working order. Empty recovery cylinders shall be evacuated and, if possible, cooled before recovery occurs.
  - The recovery equipment shall be in good working order with a set of instructions concerning the equipment at hand, and shall be suitable for the recovery of flammable refrigerants.
  - In addition, a set of calibrated weighing scales shall be available and in good working order.
  - Hoses shall be complete with leak-free disconnect couplings and in good condition. Before using the recovery machine, check that it is in satisfactory working order, has been properly maintained, and that any associated electrical components are sealed to prevent ignition in the event of a refrigerant release. Consult the manufacturer if in doubt.
  - The recovered refrigerant shall be returned to the refrigerant supplier in the correct recovery cylinder, and the relevant Waste Transfer Note arranged. Do not mix refrigerants in recovery units and especially not in cylinders.
  - If compressors or compressor oils are to be removed, ensure that they have been evacuated to an acceptable level to make certain that flammable refrigerant does not remain within the lubricant. The evacuation process shall be carried out prior to returning the compressor to the suppliers. Only electric heating of the compressor body shall be employed to accelerate this process. When oil is drained from a system, it shall be carried out safely.

# 3. CONTROL SYSTEM

## Description of Icons

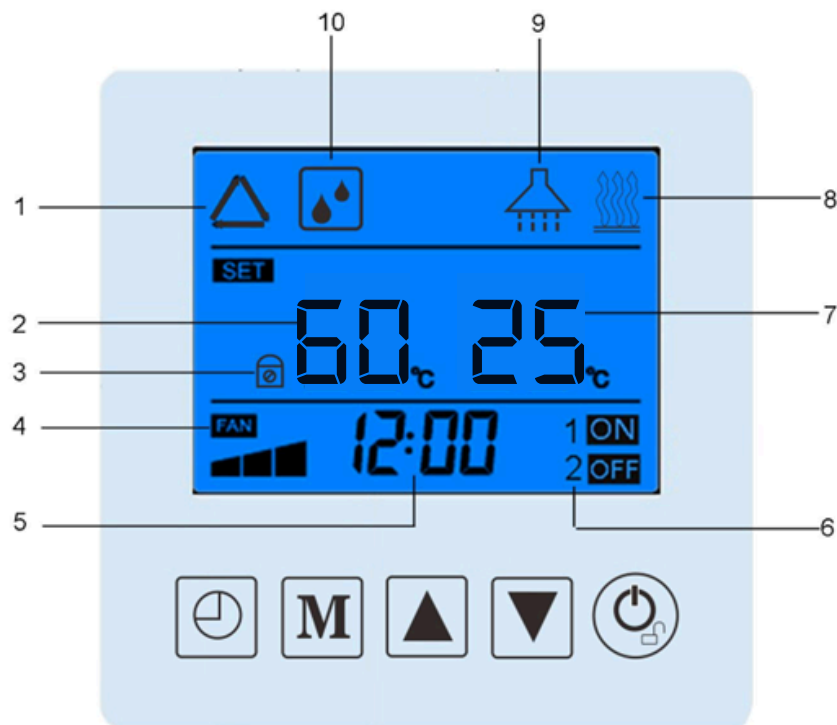

1. Compressor running
2. The setting temperature (preset to 60°)
3. Buttons locked
4. Fan running
5. Clock
6. Timer 1 & 2
7. Measured water tank temperature
8. High temp. Sterilization mode: heats at least 45% of tank water to 60°C daily
9. Heating mode
10. Defrosting mode



- Long press for 3 seconds to unlock the keys.
- When the keys are unlocked, long press for 1 second to turn the unit on or off.
- Press to return to the main interface.
- Press to clear the error when the machine is locked due to an error.



- Under the main interface, press it to review the running status.
- Long press for 3 seconds to review the parameters.



- Long press for 5 seconds to enter the clock setting.
- Short press to enter the timer setting, then work with ▲▼ to set the timer.

## Operation Instruction

### Lock/Unlock the Keys

- Unlock keys: When in lock status, press ⏻ for 3 seconds to unlock the buttons.
- Lock keys: If no operation is performed on the keys for 60 seconds, they will lock automatically.

### Turn On/Off the Unit

1. **Turn On:** Connect the power supply to the unit. The heat pump will start running automatically, or press ⏻ for 1 second to turn on the unit (refer to the status pictures below). ▲ represents that the compressor is running (refer to picture 3: Running Status).
2. **Turn Off:** When the unit is on or running, press ⏻ for 1 second to turn it off (ensure the keys are unlocked, see A).

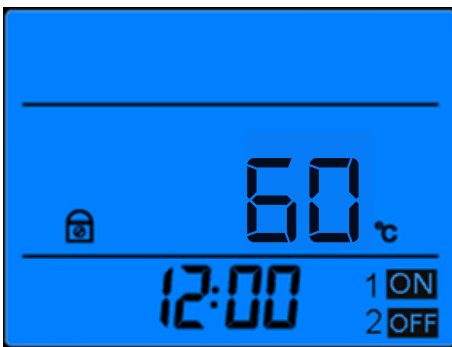

OFF Status



ON Status

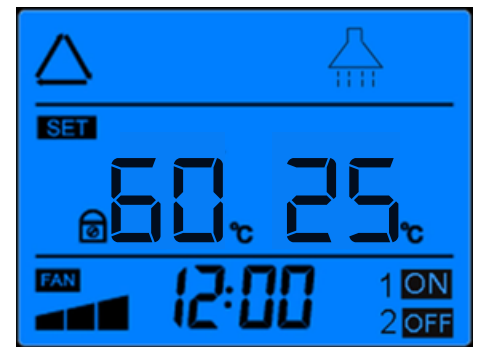

Compressor Running Status

### Set Water Temperature

This appliance is preset to a fixed water temperature of 60 °C. The temperature is not adjustable by the user.

### Set the Clock

Under the main interface, long press ⏻ for 5 seconds to enter clock setting.

- Press ⏻, the hour section will flash. Press ▲ or ▼ to set the hour.
- Then press ⏻, the minute section will flash. Press ▲ or ▼ to set the minute.
- After setting the minute, press ⏻ to save and return to the main interface. If there is no operation for 60 seconds, the setting will be saved automatically and the unit will return to the main interface.

### Set or Cancel the Timer for ON/OFF

Users can set 2 timer periods for the unit to turn on/off automatically.

- Under the main interface, press ⏻ to enter the setting of Timer 1.
- Press ⏻, the hour section will flash. Press ▲ or ▼ to set the on-time hour.
- Press ⏻, the minute section will flash. Press ▲ or ▼ to set the on-time minute.
- Press ⏻ to enter the off-time setting of Timer 1. Use the same steps above to set the off-time.
- Press ⏻ to save Timer 1 and enter Timer 2. Use the same steps to set Timer 2.

### During the setting process:

- Press **M** to cancel the current timer setting.
- To cancel **⏻** all timers, long press for 5 seconds. All timers will be cancelled.
- If there is no operation on the keypad for 30 seconds, the setting will be saved automatically and the unit will return to the main interface.
- Short press **⏻** at any time to save the setting and return to the main interface.
- The timers have a power-off memory function.

### Working Status Query

Under the main interface, press **M** to view the working status values (refer to the table below).

No.	Description	Range
0	PCB version	5
1	Error code	Current code or latest code
2	Water tank/ water inlet temperature	0°C~99°C
4	Water outlet temperature	-31°C~99°C
5	Ambient temperature	-31°C~99°C
6	Reserved	
9	Current setting value	0~40A
10	Compressor current	measured value
11	Compressor discharge temperature	0°C~125°C
12	Coil temperature	-31°C~99°C
13	Compressor suction temperature	-31°C~99°C
14	Opening of electronic expansion valve	measured value

### Review/Set the Parameters (for Technician Only)

- When the heat pump is ON or OFF, under the main interface, long press **M** for 3 seconds to enter the review menu. Press **▲** or **▼** to review the parameters.
- During the review, press **M**, then press **▲** or **▼** to adjust a parameter. Press **M** to save and return to the review interface.
- If there is no operation on the keypad for 30 seconds, it will return to the main interface automatically, or you can press **⏻** to return manually.
- Under the main interface, long press **⏻** + **▲** + **▼** simultaneously for 3 seconds. After 10 seconds, all settings will be restored to the default values, and the heat pump will turn off.

## Parameters Table

### Table 3.2

No.	Parameters	Range	Default value
L0	Water tank temp. setting	35°C~60°C	60°C
L1	N/A		
L2	N/A		
L3	Temperature difference setting to start/stop compressor (Refer to the note below)	1°C~40°C	See Table 3.3 (model-specific)
L12	N/A		
L15	N/A		

### Table 3.3

Heat Pump Model	Default Operation Mode	Default Heat Pump Setting (setpoint°C/deadband°C)	Default Electric Element Setting	Legionella control
OMNIXHP-180-R290	Standard	60/5	N/A	45% to 60°C daily
OMNIXHP-250-R290	Standard	60/10	N/A	45% to 60°C daily
OMNIXHP-340-R290	Standard	60/11	N/A	45% to 60°C daily
OMNIXHP-420-R290	Standard	60/12	N/A	45% to 60°C daily

Note:

1. Set the temperature difference between the measured water temperature and the desired water temperature.
2. By setting this temperature difference, the unit can automatically start and stop.
3. For example, with a deadband of X°C (see Table 3.3 for your model's default): when the measured temperature is X°C below the desired water temperature, the unit will start automatically. It will not stop until the measured temperature reaches the desired water temperature.

# Protection

## **Communication Protection 09E**

When there is no signal from the keypad to the PCB for 20 seconds (B wire), or there is no signal from the PCB to the keypad for 60 seconds (A wire — the process requires 2 minutes), the keypad screen will display 09E.

## **Water Tank Temperature Sensor Protection 15E**

## **Ambient Temperature Sensor Protection 12E**

## **Water Outlet Temperature Sensor Protection 13E**

## **Coil Temperature Sensor Protection 10E**

## **Compressor Suction Temperature Sensor Protection 64E**

## **Compressor Discharge Temperature Sensor Protection 18E**

## **Ambient Temperature Too Low Protection 72E**

## **High Pressure Protection 03E**

## **Low Pressure Protection 04E**

## **Compressor Discharge Temperature Too High Protection 20E**

## **Compressor Undercurrent/Overcurrent Protection 40E/02E**

When the compressor runs for 3 seconds, the current is detected. If the current is  $\leq 1A$  for 3 seconds, the heat pump will stop. The system will recover after 3 minutes. An alarm will sound if the fault occurs 5 times within 1 hour.

- Error code 40E indicates undercurrent.
- Error code 02E indicates overcurrent.

## **Water Outlet Temperature Too High Protection 05E**

## **Ambient Temperature + Water Outlet Temperature Too High Protection**

**Ambient Temperature Too High Protection** (no error code, automatically triggered according to ambient temperature).

## **Compressor Delay Protection**

- When the power supply is connected to the unit and it starts up, the compressor will begin operating after 30 seconds to protect the compressor.
- When restarting the unit after it has been turned off, the compressor will begin operating after 3 minutes to protect the compressor.

At least 45% of the water contained within the storage tank must be heated to a minimum of 60°C daily.

# 4. TROUBLESHOOTING

Table 4.1

Fault Code	Fault	Possible Causes	Treatment
03E	High pressure switch fault (protection when interrupted)	<ul style="list-style-type: none"> <li>• High pressure switch damaged</li> <li>• Water tank lacks water</li> <li>• The system is jammed, the probe of the sensor has fallen down</li> <li>• Excessive refrigerant</li> <li>• Uncondensed gas in the refrigerant system</li> </ul>	<ul style="list-style-type: none"> <li>• Replace the high pressure switch</li> <li>• Refill water</li> <li>• Check and clean the system, retighten the probe</li> <li>• Drain excess refrigerant</li> <li>• Remove uncondensed gas</li> </ul>
04E	Low pressure switch fault (protection when interrupted)	<ul style="list-style-type: none"> <li>• Low pressure switch damaged</li> <li>• Inadequate refrigerant</li> <li>• Evaporator fins are dirty</li> </ul>	<ul style="list-style-type: none"> <li>• Replace the low pressure switch</li> <li>• Detect and repair leaks, then refill with the correct amount of refrigerant</li> <li>• Clean the fins</li> </ul>
05E	Overheating of the outlet water	<ul style="list-style-type: none"> <li>• Clogged water line</li> <li>• Water outlet temperature sensor fault</li> </ul>	<ul style="list-style-type: none"> <li>• Check the water system and the pump</li> <li>• Check the electrical resistance of the sensor</li> </ul>
09E	Communication error (the control panel cannot receive information from the PCB)	<ul style="list-style-type: none"> <li>• Open circuit or short circuit between the operation panel and PCB</li> </ul>	<ul style="list-style-type: none"> <li>• Renovate or replace the wire between the control panel and PCB</li> </ul>
11E	Coil sensor fault (open circuit or short circuit)	<ul style="list-style-type: none"> <li>• Sensor open circuit</li> <li>• Probe of the sensor has fallen down</li> <li>• Sensor short circuit</li> </ul>	<ul style="list-style-type: none"> <li>• Reconnect the wiring of the sensor</li> <li>• Retighten the probe</li> <li>• Renovate wiring and remove faults</li> </ul>

12E	Environment sensor fault (open circuit or short circuit)	<ul style="list-style-type: none"> <li>• Sensor open circuit</li> <li>• Probe of the sensor has fallen down</li> <li>• Sensor short circuit</li> </ul>	<ul style="list-style-type: none"> <li>• Reconnect the wiring of the sensor</li> <li>• Retighten the probe</li> <li>• Renovate wiring and remove faults</li> </ul>
15E	Water-tank sensor fault (open circuit or short circuit)	<ul style="list-style-type: none"> <li>• Sensor open circuit</li> <li>• Probe of the sensor has fallen down</li> <li>• Sensor short circuit</li> </ul>	<ul style="list-style-type: none"> <li>• Reconnect the wiring of the sensor</li> <li>• Retighten the probe</li> <li>• Renovate wiring and remove faults</li> </ul>

**Note:** When a fault occurs, the corresponding fault code will flash on the screen and an alarm will sound.

**Table 4.2**

Fault Condition	Possible Causes	Treatment
The unit doesn't work	<ul style="list-style-type: none"> <li>• Power failure</li> <li>• Bad connection to the power supply</li> <li>• Fuse blown</li> </ul>	<ul style="list-style-type: none"> <li>• Turn off the switch and check the power source</li> <li>• Find the cause and repair it</li> <li>• Replace the fuse</li> </ul>
Low heating capacity	<ul style="list-style-type: none"> <li>• Inadequate refrigerant</li> <li>• Drying filter blockage</li> <li>• Air-side heat exchanger is inefficient</li> </ul>	<ul style="list-style-type: none"> <li>• Detect and repair leaks, then refill with the correct amount of refrigerant</li> <li>• Replace the drying filter</li> <li>• Clean the heat exchanger</li> </ul>
The compressor doesn't work	<ul style="list-style-type: none"> <li>• Power failure</li> <li>• Compressor relay damaged</li> <li>• Poor connection</li> <li>• Overheating protection activated</li> </ul>	<ul style="list-style-type: none"> <li>• Inspect and resolve the issue</li> <li>• Replace the PCB</li> <li>• Check and repair the connection</li> <li>• Resolve overheating protection issue</li> </ul>
The compressor works but is too noisy	<ul style="list-style-type: none"> <li>• Liquid refrigerant entering the compressor</li> <li>• Interior components damaged</li> <li>• Inadequate refrigeration oil</li> </ul>	<ul style="list-style-type: none"> <li>• Check the expansion valve</li> <li>• Replace the compressor</li> <li>• Add adequate refrigeration oil</li> </ul>
Excessive discharge pressure	<ul style="list-style-type: none"> <li>• Too much refrigerant</li> <li>• Non-condensed gas in the refrigeration cycle</li> </ul>	<ul style="list-style-type: none"> <li>• Remove the excess refrigerant</li> <li>• Vent the gas out</li> </ul>

Low suction pressure	<ul style="list-style-type: none"><li>• Drying filter blockage</li><li>• Lack of refrigerant Excessive pressure drop in the heat exchanger</li></ul>	<ul style="list-style-type: none"><li>• Replace the filter</li><li>• Detect and repair leaks, then refill with the correct amount of refrigerant</li><li>• Check the opening of the electronic expansion valve</li></ul>
----------------------	--	--

# 5. WIRING DIAGRAM

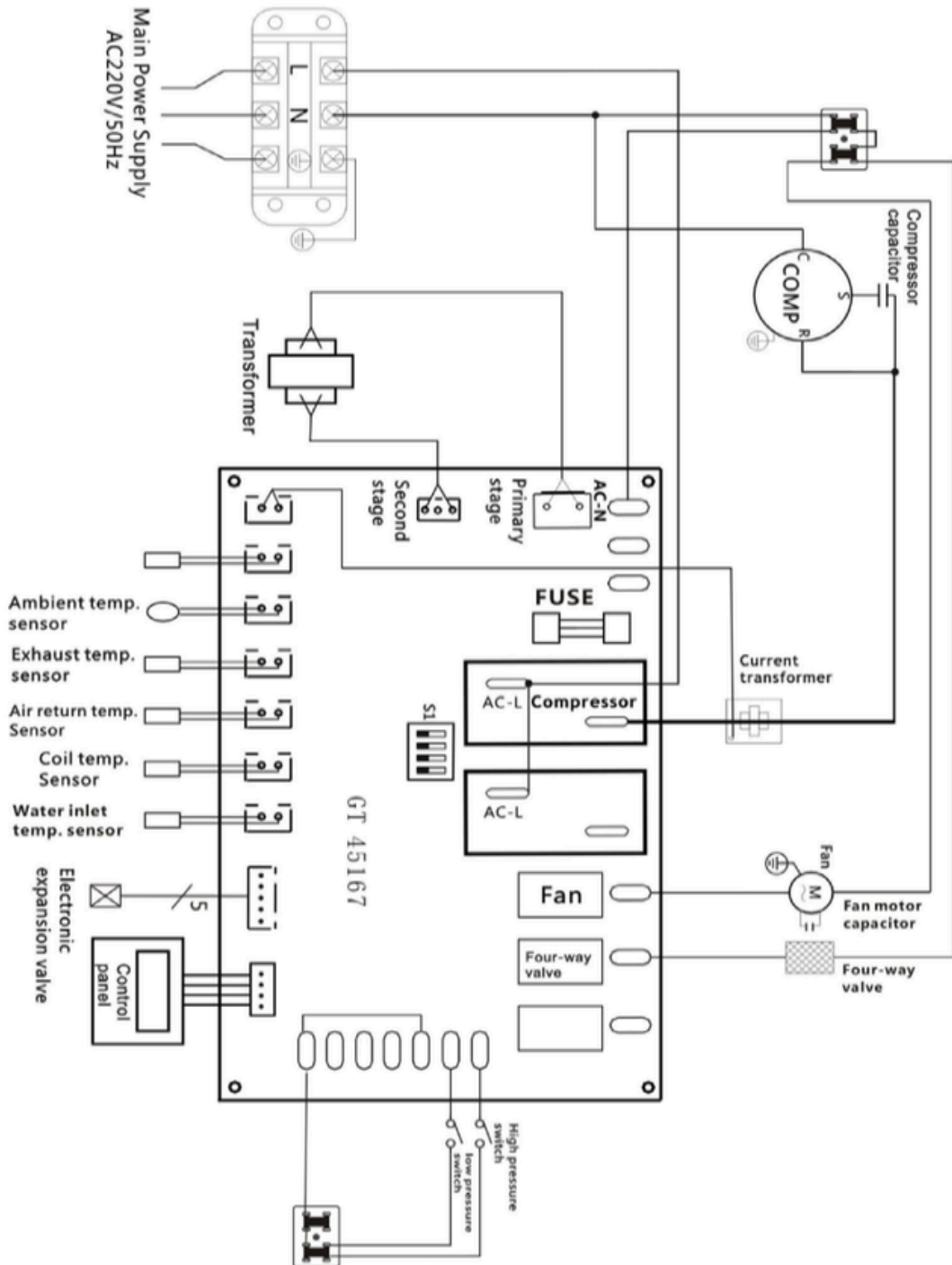

## Fuse Information:

Fuse model: 524

Technical parameters: 5A / 250V, slow-blow,  $\Phi 5 \times 20$  mm, ceramic

# APPENDICES

## Appendix 1: How to Connect the Heat Pump Controller to Your Cell Phone

- After the heat pump is connected to the power supply, the Wi-Fi function of the controller can be activated.
- The controller should be installed in a location where a good quality Wi-Fi signal can be received.
- The Wi-Fi function can be set whether the heat pump controller is ON or OFF.

**1** Connect your cell phone to your Wi-Fi.  
Turn on the Location and Bluetooth functions on your cell phone.

**2** Search for the app **“Smart Life”** and install it.

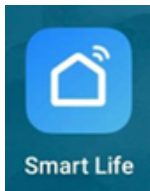
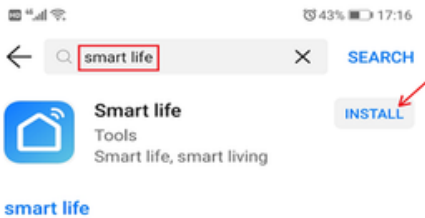

Open the **Smart Life** app on your cell phone.

**3** Register an account or log in with an existing account (refer to the picture on the bottom).

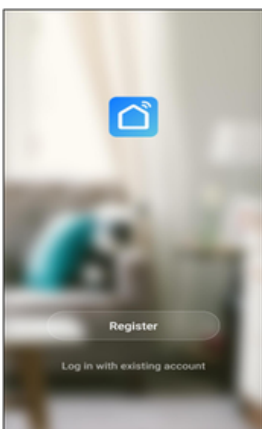

4

After logging into the Smart Life app, tap the “+” icon at the upper right corner, then select **Add Device**.

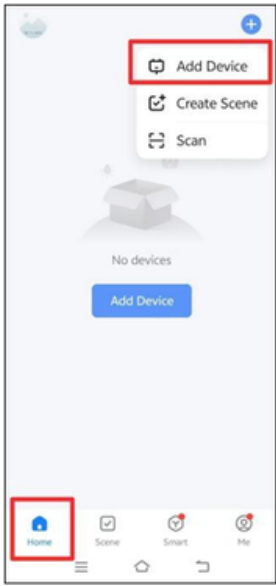

5

On the controller, long press **M** and **▼** simultaneously for 5 seconds until an icon begins blinking on the controller screen (refer to the picture below).



6

On your mobile phone, select **Heat Pump**, enter your Wi-Fi information, and wait for the process to complete.

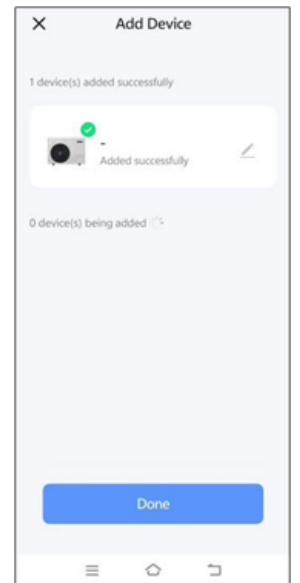
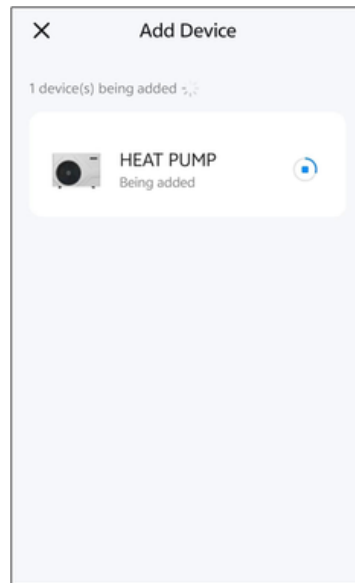
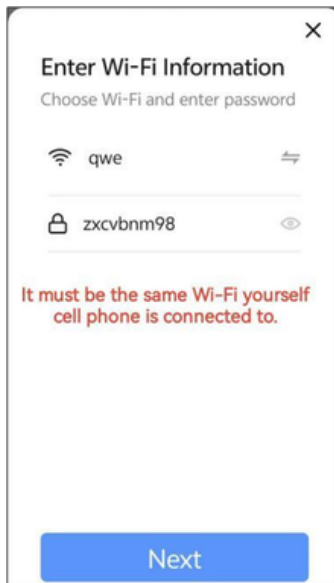

Once successfully added:

- The name of the water heater can be renamed. Tap icon  , then enter the new name.
- The heat pump water heater can now be controlled by your cell phone.

## Functions available in the app:

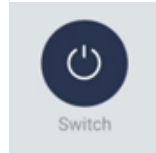

**"Switch" button** — turns the unit ON or OFF.

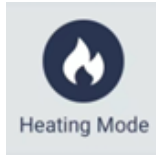

**"Heating Mode" button** — enables heating operation.



**"+, -" button** — Adjusts the set temperature of the water tank.

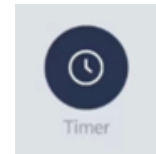

**"Timer" button** — Sets the timer for ON/OFF operation.

### Note:

- **Cooling Mode** and **Auto Mode** are for other models. Please do not use them.
- If **Cooling Mode** or **Auto Mode** is selected by mistake, simply press **Heating Mode** to return to normal operation.

# Appendix 2: How to Set the Timer

1

Press **Timer** (bottom right-hand of the screen), then press **Add**.

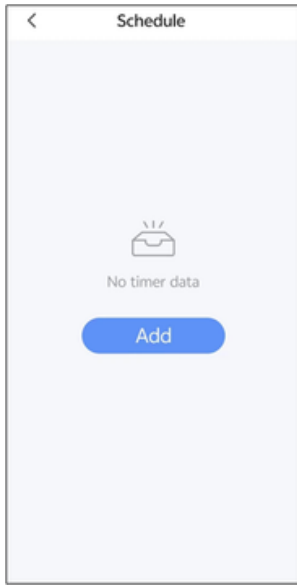

For example, we will set the unit to switch on at 12:00 and switch off at 14:00.

2

Set the switch-on time:



Select the time 12:00.

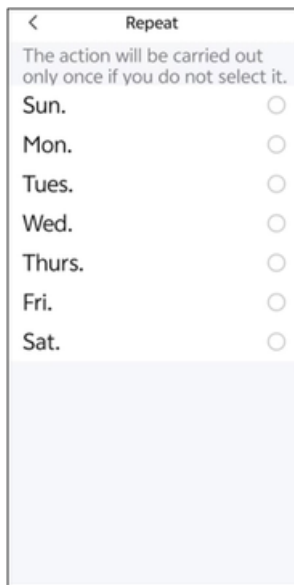

Set the **Repeat** option according to your needs.



Turn the **Switch ON**.

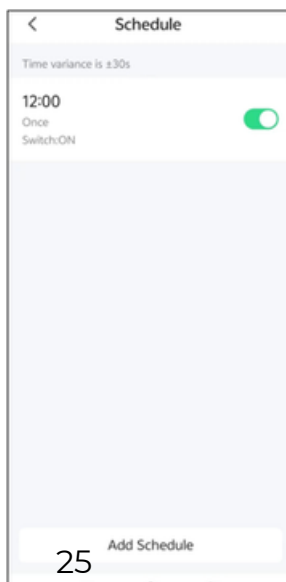

Tap **Done**, then press **Save** (top right-hand corner of the screen).

# 3

Set the switch-off time:

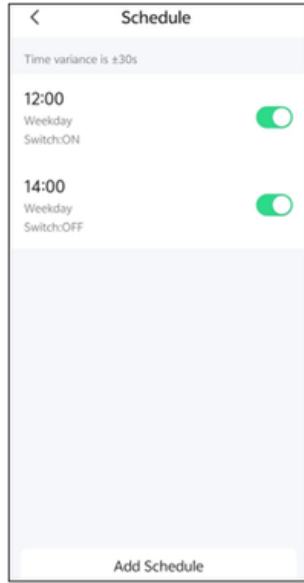

- Press **Add Schedule** (bottom of the screen).
- Select the time **14:00**.
- Set the **Repeat** option according to your needs.
- Turn the **Switch OFF**.
- Tap **Done**, then press **Save** (top right-hand corner of the screen).

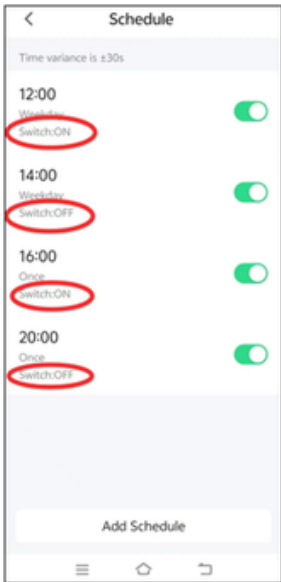

- You may add more switch-on/off schedules according to your needs by pressing **Add Schedule**. For example, refer to the picture on the left.

# DISPOSAL

Do not dispose of this product as unsorted municipal waste. Separate collection of such waste for special treatment is necessary.

Do not dispose of electrical appliances as unsorted municipal waste; use separate collection facilities.

Contact your local government for information regarding the collection systems available. If electrical appliances are disposed of in landfills or dumps, hazardous substances can leak into the groundwater and enter the food chain, damaging your health and well-being.

